

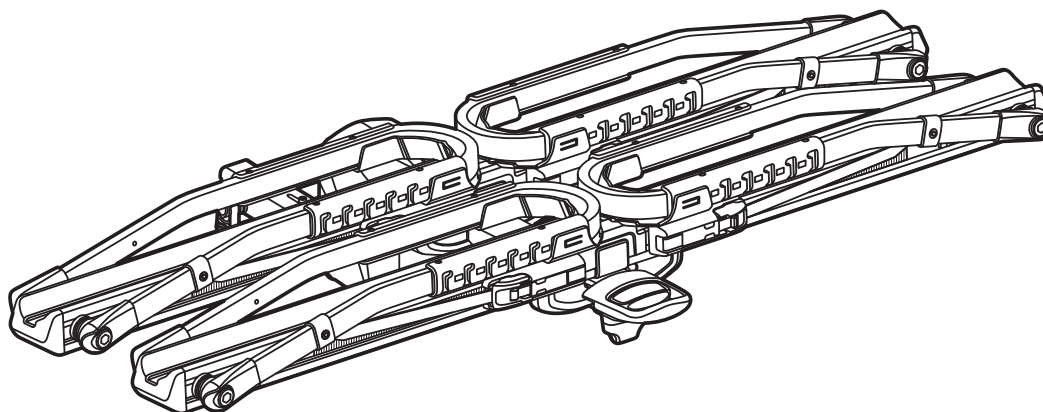





INH123

Installation instructions Instructions d'installation Instrucciones de instalación



INH123





EN : Please be sure to follow the following matters for safe usage of this product.

-  **Warning** Failure to follow this warning can result in serious accidents including death or serious injury.
-  **Precautions** Failure to follow precautions can result in injury, damage to the product, vehicle, or load.
-  **Note** Things that you should know are described in this section.

FR : Veuillez vous assurer de bien respecter les points suivants pour garantir une utilisation de ce produit en toute sécurité.

-  **Avertissement** En cas de non-respect de cet avertissement, des accidents graves, entraînant des blessures graves ou la mort pourraient se produire.
-  **Précautions** Le non-respect des précautions peut entraîner des blessures, ou encore endommager le produit, le véhicule ou la charge.
-  **Remarque** Cette section présente des informations que vous devriez connaître.

ES : Asegúrese de seguir las siguientes cuestiones para la utilización segura de este producto.

-  **Advertencia** El no respetar esta advertencia puede ocasionar accidentes graves, incluso la muerte o heridas graves.
-  **Precauciones** Si no sigue estas precauciones, pueden producirse heridas, daños al producto, al vehículo o a la carga.
-  **Nota** Lo que debe saber se describe en esta sección.

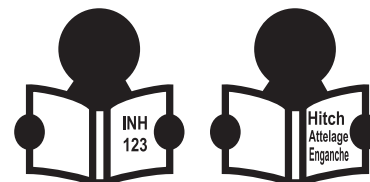

Possible installation size / Dimension possible d'installation / Tamaño de instalación posible

Receiver/Récepteur/Receptor

Minimum/Minimum/Mínimo
1 1/2" (38mm)

Minimum/Minimum/Mínimo
1 1/2" (38mm)

Max 80lbs.(36kg)

Max 150lbs.(68kg)

Class / Classe / Clase

RV

Trailer

EN : Warning Do not install this product to RV's, trailers or towed vehicles.

FR : Avertissement N'installez pas ce produit sur un VR, une remorque ou un véhicule remorqué.

ES : Advertencia No instale este producto en caravanas, remolques o vehículos remolcados.

Loading Condition / Conditions de charge / Condiciones de carga

34"
(850mm) 51"
(1300mm)

20" 29"

18c 5"

No loading / Pas de chargement / Sin carga

Product contents / Contenu du produit / Contenido del producto

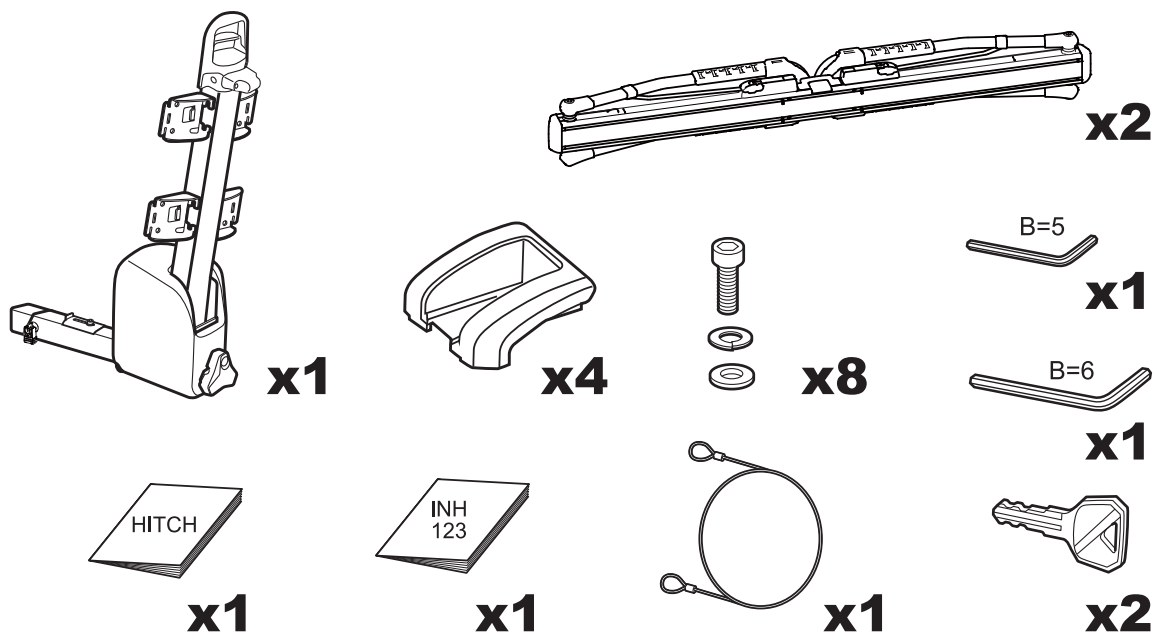

Installation to vehicle / Installation sur le véhicule / Instalación en el vehículo

1

EN : **Warning** Be sure to use safety bolt.

FR : **Avertissement** Assurez-vous d'utiliser des crans de sécurité.

ES : **Advertencia** Asegúrese de utilizar los pernos de seguridad.

2

EN : **Note** Some gap will be produced when the distance between the receiver pin hole to the receiver rear edge is 2" (50mm) or shorter.

FR : **Remarque** Un espace apparaît quand la distance entre le trou d'axe du récepteur et le bord arrière du récepteur est de 2" (50 mm) ou moins.

ES : **Nota** Quedará cierta separación cuando la distancia entre el orificio del pasador del receptor y el extremo trasero del receptor sea de 2 pulgadas (50 mm) o inferior.

3

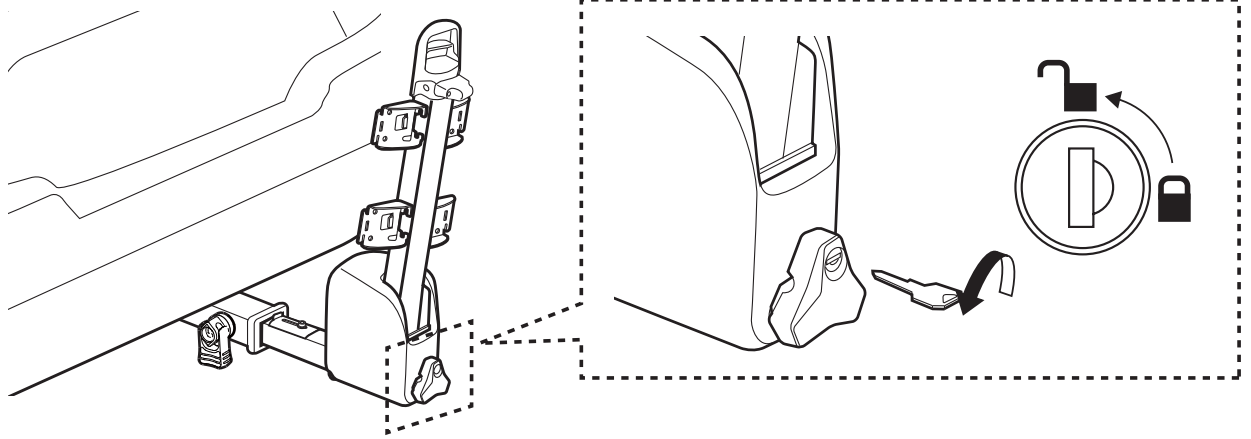

4

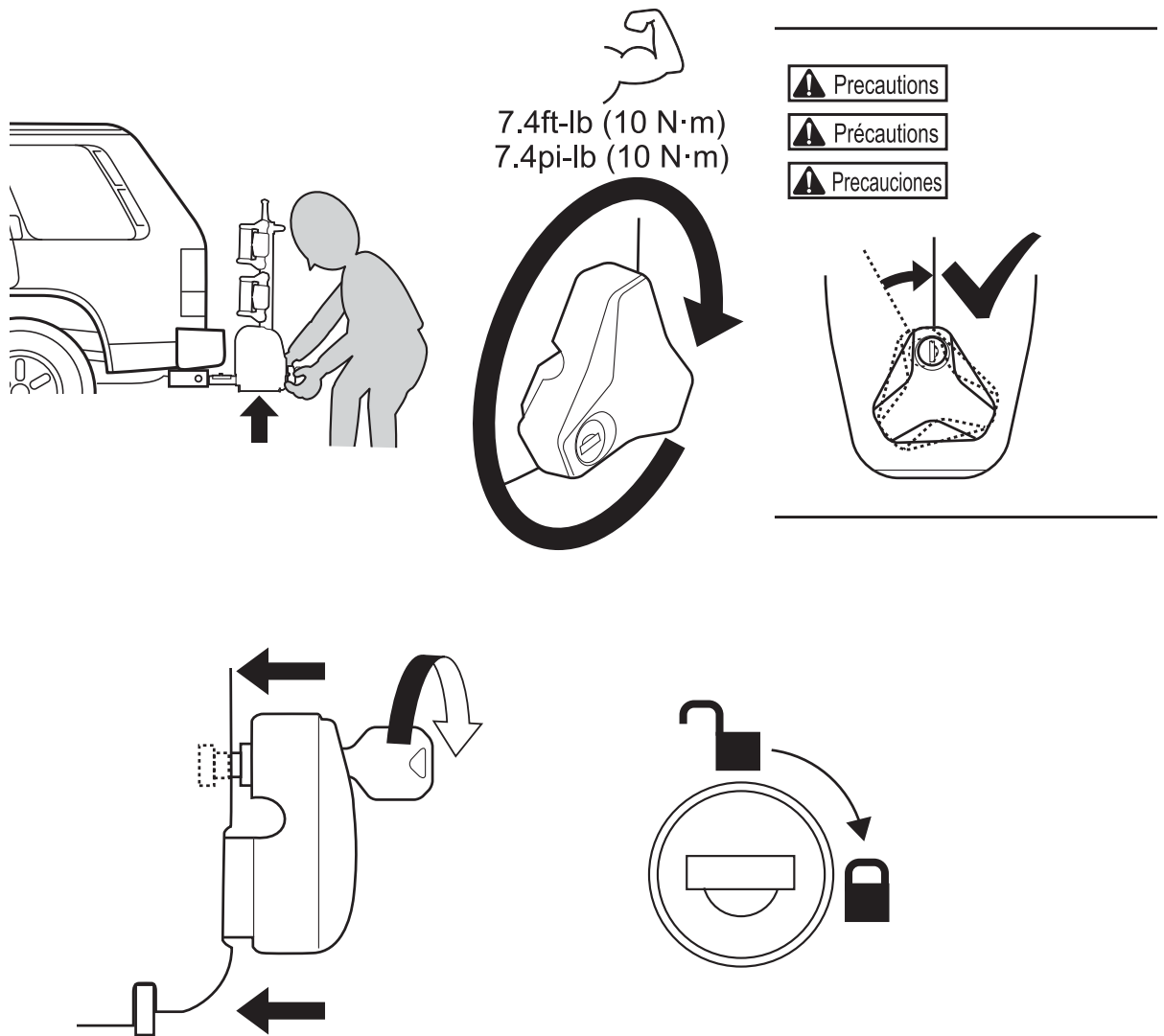

5

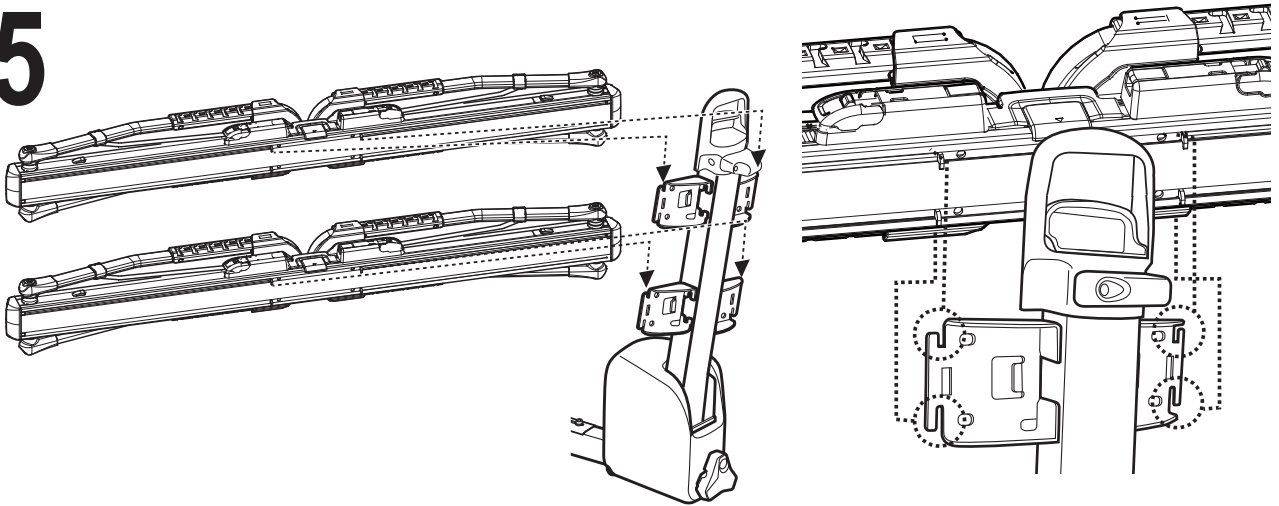

6

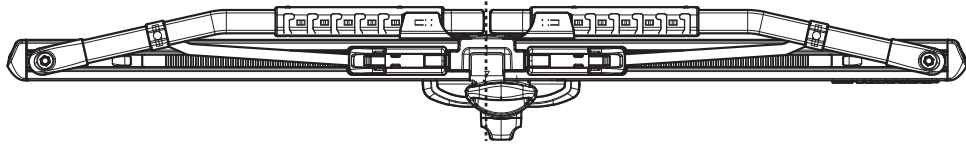
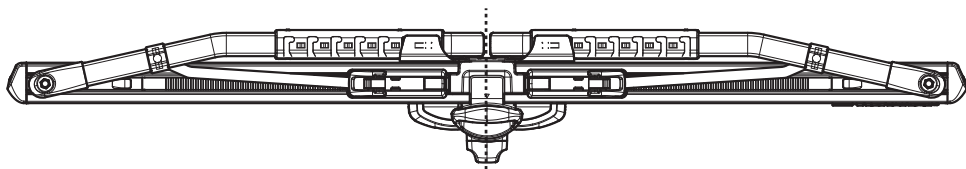

7

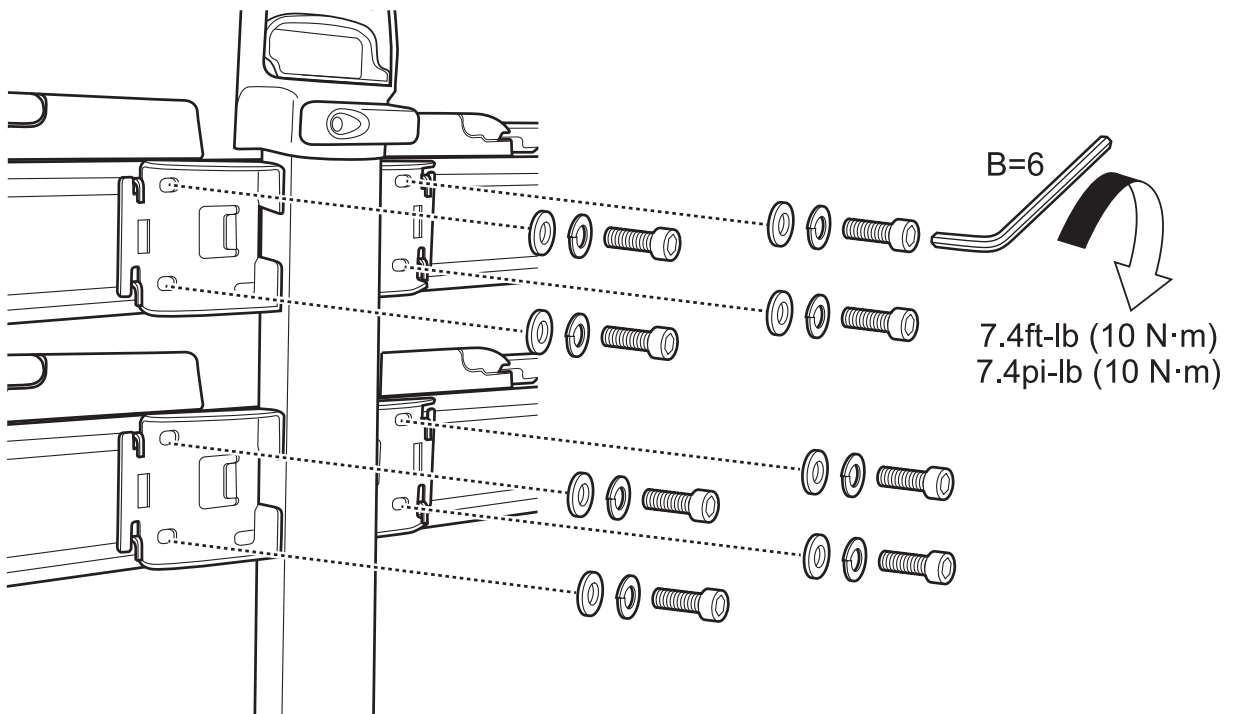

8

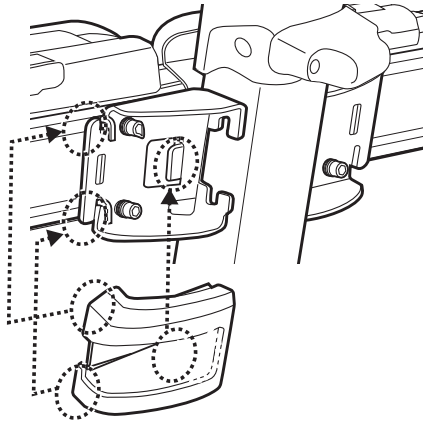
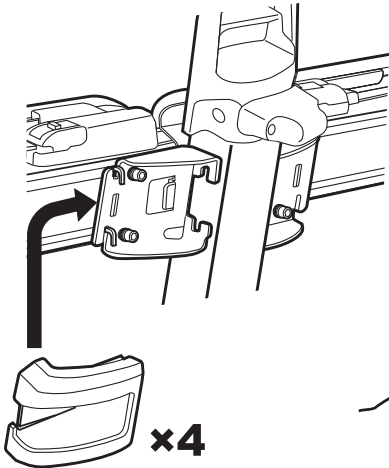

EN :  **Precautions**

Check that the 3 tabs are firmly hooked.

FR :  **Précautions**

Vérifiez que les 3 languettes sont bien accrochées.

ES :  **Precauciones**

Verifique que las 3 lengüetas están firmemente enganchadas.

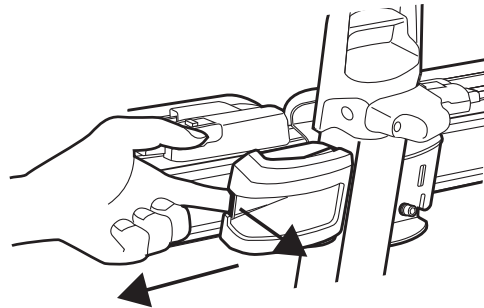

EN :  **Note**

Raise and slide the center lever tab outwards to remove the mount cover.

FR :  **Remarque**

Soulevez et faites glisser la languette de levier centrale vers l'extérieur pour retirer le couvercle de montage.

ES :  **Nota**

Eleve y deslice la lengüeta de la palanca central hacia fuera y retire la cubierta del soporte.

Loading a bike / Installation d'un vélo / Sujetar una bicicleta

1

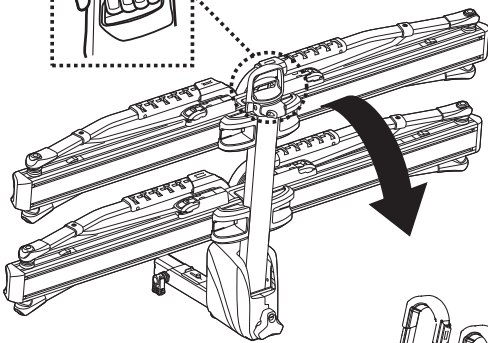
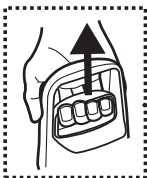

EN :  **Warning**

Confirm that red part must be invisible.

FR :  **Avertissement**

Vérifiez que la partie rouge doit être invisible.

ES :  **Advertencia**

Confirme que la parte roja no esté visible.

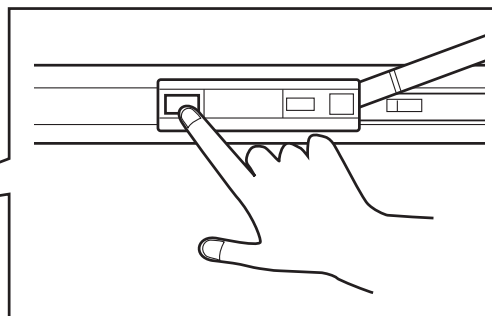
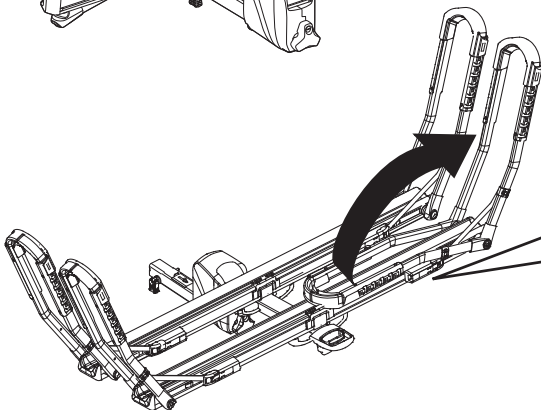
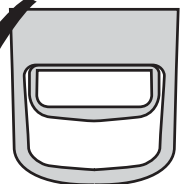

2

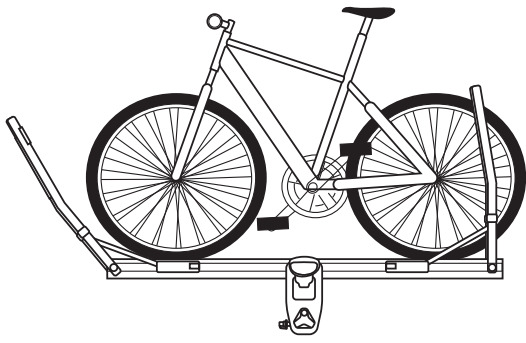

⚠ Precautions

⚠ Précautions

⚠ Precauciones

Heavy
Lourd
Pesado

Light
Léger
Liviano

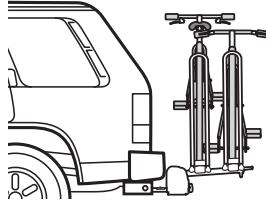

⚠ Precautions

⚠ Précautions

⚠ Precauciones

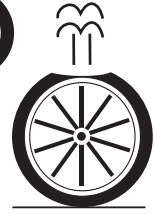

3

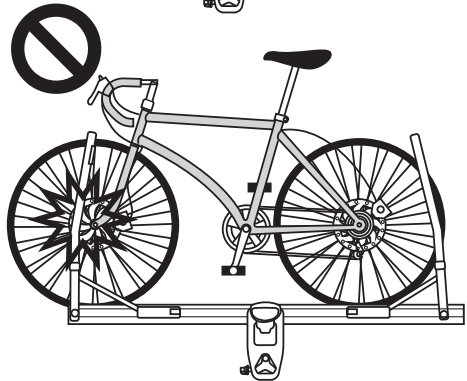
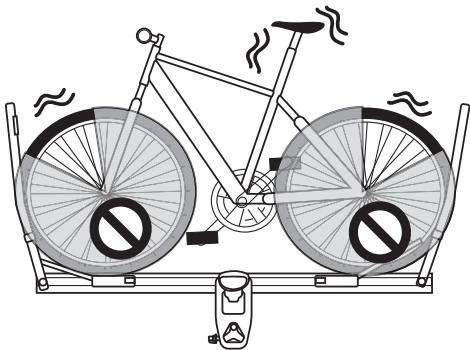
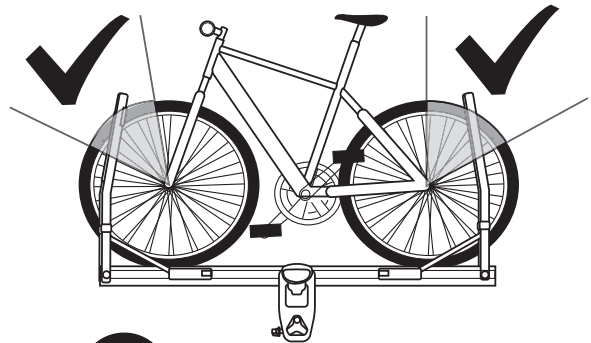
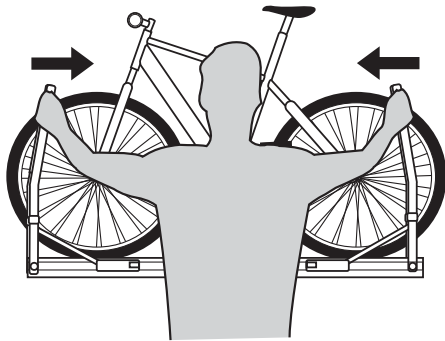

4

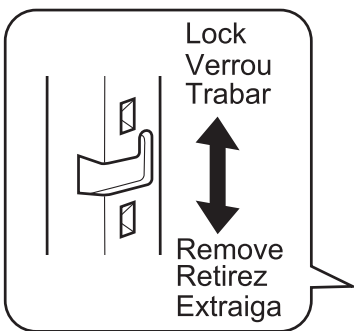

Lock
Verrou
Trabar



Remove
Retirez
Extraiga

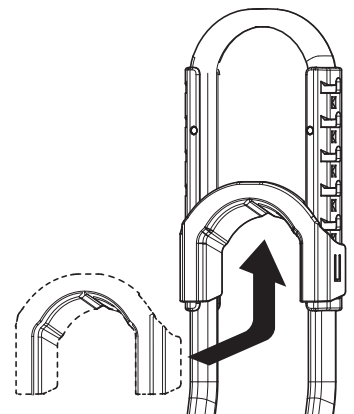
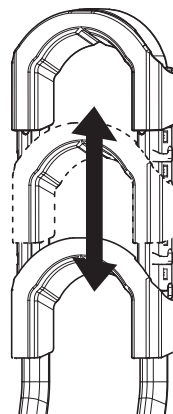
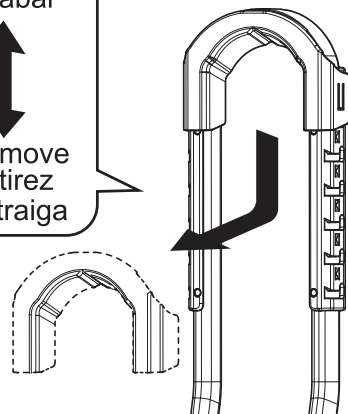

5 Loading a bike sideways by lowering the arm. / Chargez un vélo de côté en abaissant le bras. / Cargar una bicicleta lateralmente bajando el brazo.

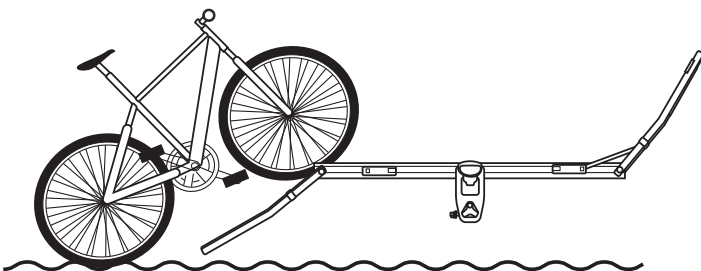
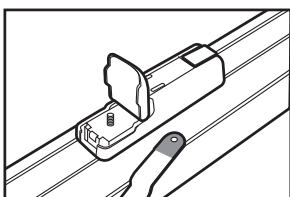
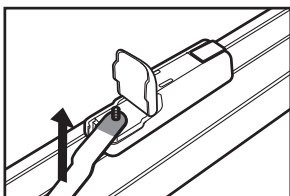
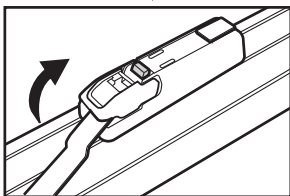
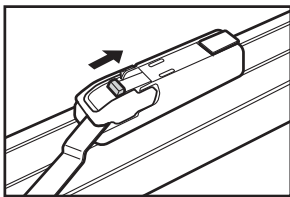
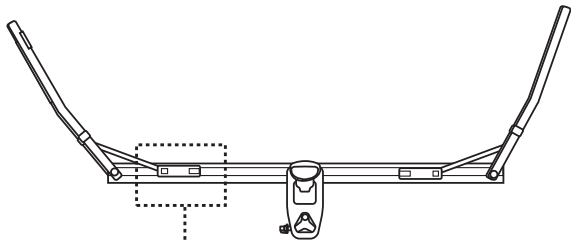

EN : Note Lower the arm to load your bike more easily.

FR : Remarque Abaissez le bras pour faciliter le chargement du vélo.

ES : Nota Baje el brazo para cargar la bicicleta de forma más sencilla.

EN : Precautions To avoid damage, keep the arm off the ground when lowering it.

FR : Précautions Afin d'éviter tout dommage, évitez que le bras ne touche le sol quand vous l'abaissez.

ES : Precauciones Para evitar daños, mantenga el brazo separado del suelo al bajarlo.

EN : Warning Before driving, check that the arm link is locked.

FR : Avertissement Avant de démarrer, vérifiez que le bras d'articulation est verrouillé.

ES : Advertencia Antes de conducir, verifique que el brazo articulado está trabado.

EN : Note To facilitate your bike loading, use Ramp option (IOP20), sold separately.

FR : Remarque Pour faciliter le chargement du vélo, utilisez l'option de rampe (IOP20) vendue séparément.

ES : Nota Para cargar su bicicleta de forma más sencilla, utilice el accesorio de rampa (IOP20), vendido por separado.

6

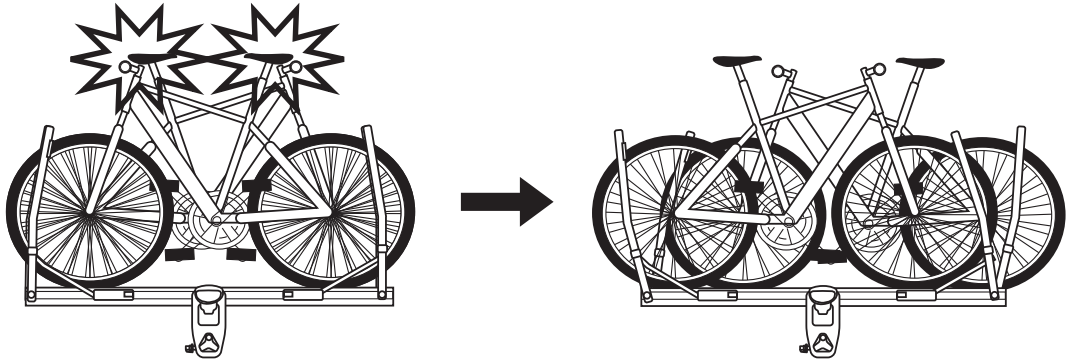

EN :  Warning Do not load a bike that exceeds the car width.

FR :  Avertissement Ne chargez pas un vélo qui dépasse la largeur de la voiture.

ES :  Advertencia No cargue una bicicleta que exceda el ancho del auto.

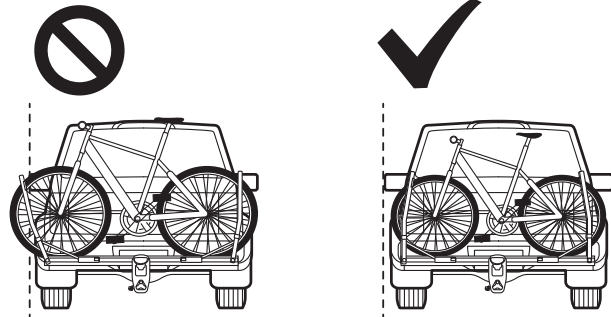

7

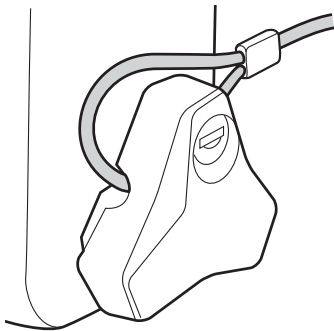

Tilt down / Inclinaison vers le bas / Inclinar hacia abajo

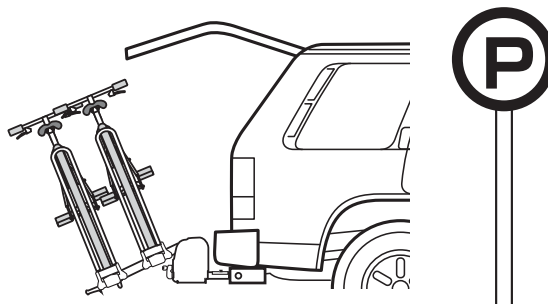
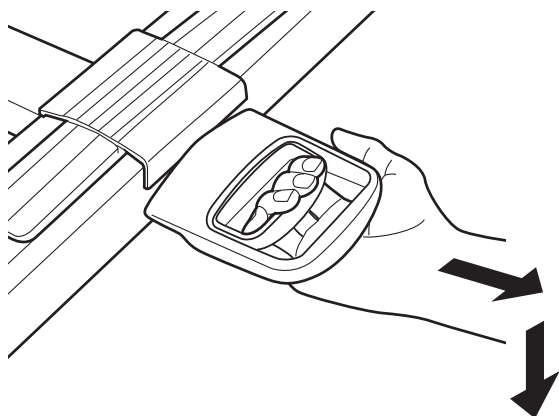

EN :  Warning Confirm that red part must be invisible.

FR :  Avertissement Vérifiez que la partie rouge doit être invisible.

ES :  Advertencia Confirme que la parte roja no esté visible.

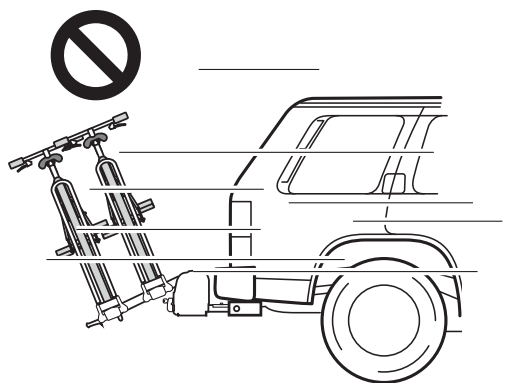
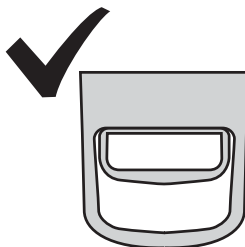

Spare parts / Pièces de rechange / Repuestos

EN : Please specify part name when ordering spare parts.

FR : Veuillez indiquer le nom de la pièce lors de la commande de pièces de rechange.

ES : Especificue el nombre de la pieza cuando pida repuestos.

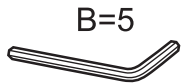

B=5
EN : Hex wrench
FR : Clé hexagonale
ES : Llave hexagonal

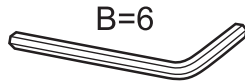

B=6
EN : Hex wrench
FR : Clé hexagonale
ES : Llave hexagonal



ISP 1066
EN : Wire cable
FR : Câble métallique
ES : Cable

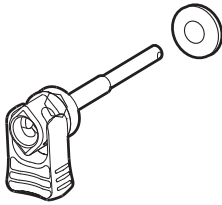

ISP1223
EN : Safety Bolt
FR : Boulon de sécurité
ES : Perno de seguridad

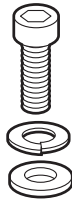

EN : Cap Bolt M8 set
FR : Ensemble de caches boulons M8
ES : Conjunto de perno de tapa M8

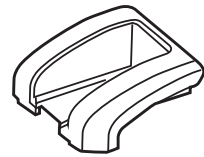

ISP 1190
EN : Mount cover
FR : Couvercle de montage
ES : Cubierta del soporte

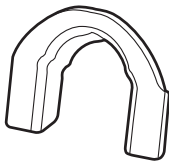

ISP1224
EN : Tire adjuster
FR : Organe de réglage de pneu
ES : Ajustador de neumáticos

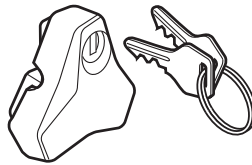

ISP 1074
EN : Knob
FR : Bouton
ES : Perilla

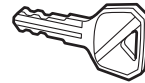

EN : Key
Key number is not changeable
FR : Clé
Le numéro de clé n'est pas modifiable
ES : Llave
El número de llave no es intercambiable

Contact Information / Coordonnées / Información de contacto

EN : We do not accept any liability for accidents, damage or injury caused by incorrect installation or use, modification, or natural disaster. Specifications and appearance of the carrier system and genuine replacement parts are subject to change without prior notice in the interest of product improvement.

FR : Nous ne pouvons être tenus responsables d'accidents, de dommages ou de blessures provoqués par une installation ou un usage incorrects, par une modification du dispositif ou par une catastrophe naturelle. Les spécifications et l'apparence du dispositif de support et des pièces de rechange authentiques sont sujettes à modification sans préavis pour fin d'amélioration du produit.

ES : No asumimos ninguna responsabilidad por accidentes, daños u otros perjuicios ocasionados por su incorrecta instalación, uso, modificación o por desastres naturales. Las especificaciones y apariencia del sistema y piezas de repuesto originales del portacargas están sujetas a cambio sin previo aviso en razón de mejora del producto.



CAR MATE USA, Inc.

383 Van Ness Ave., Suite 1603
Torrance, CA 90501
support@innoracks.com
www.innoracks.com