

Before using this product, carefully read this installation instructions for proper use. Keep this installation instructions in a safe place. If you are to give this product to a third person, provide him/her with this instructions as well to ensure safe use.

## INA394

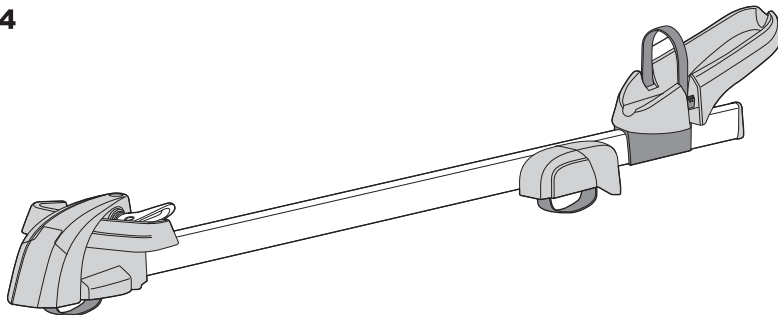

**Warning** Failure to follow this warning can result in serious accidents including death or serious injury.

- Confirm the stability and strength of the carrier base onto which this product is to be installed, and attach it securely.
- Adjust the front and rear spaces of the base carrier between 23.6"to 43.0" (600-1100mm).
- Confirm that the knob is securely tightened before driving the vehicle.
- Do not alter this product.
- Do not load a bicycle that does not conform with this product. Do not load 2 or more bicycles on one attachment.
- Drive safely especially when the carrier is loaded.
- Lock securely while driving.

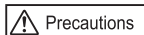

**Precautions** Failure to follow precautions can result in injury, damage to the product, vehicle, or load.

- This product is not anti-theft. Do not leave loads on the carrier for hours.

## Product contents

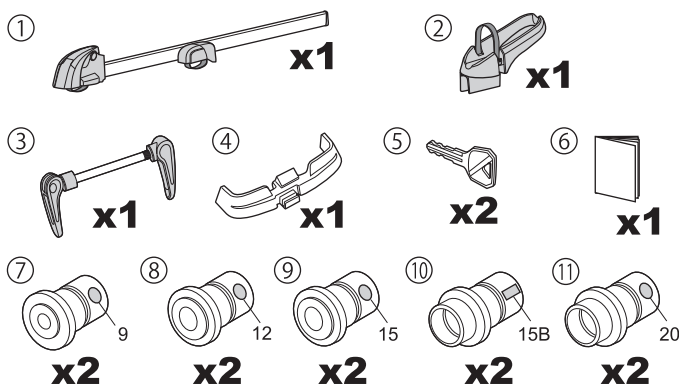

NO.	Parts
①	Main unit
②	Cradle
③	Quick lever ASSY
④	Quick release guard
⑤	Key
⑥	Installation instructions
⑦	Adaptor Φ9mmx100
⑧	Adaptor Φ12mmx100
⑨	Adaptor Φ15mmx100
⑩	Adaptor Φ15mmx110
⑪	Adaptor Φ20mmx110

## Check before Use

This product can be attached to the INNO basic bar and the vehicle genuine base carrier (square type/crossbar). To attach to the base carrier, securely install in accordance with the Installation Instructions.

### ■ Crossbar fit size

(Vehicle genuine base carrier)

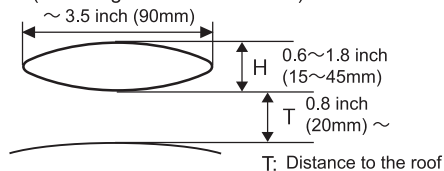

### ■ Required mounting width

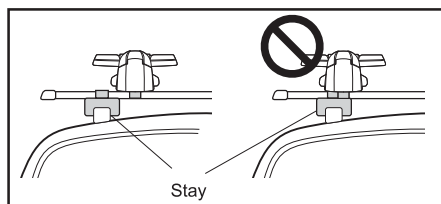
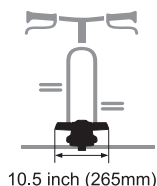

### ⚠ Warning

Confirm the stability and strength of the base carrier onto which this product is to be installed, and attach it securely. If the strength of the base carrier is not sufficient, do not mount.

It cannot be mounted by striding over the stay.

## Conforming bicycle

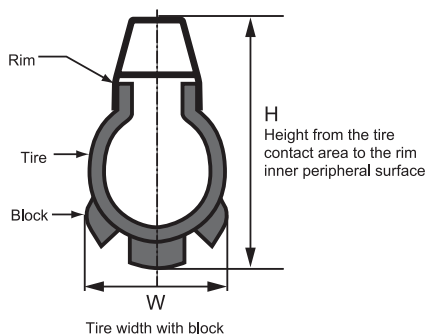

### ■ Front hub type

Quick release :  $\Phi 9\text{mm}$

Thru-axle :  $\Phi 12 \times 100\text{mm}$ ,  $\Phi 15 \times 100\text{mm}$ ,  
 $\Phi 15 \times 110\text{mm}$ ,  $\Phi 20 \times 110\text{mm}$

### ■ Wheelbase length : ~51 inch (1300mm)

### ■ Rear tire/rim size

W: ~2.8 inch (72mm)

H: ~3.3 inch (85mm)

## Warning

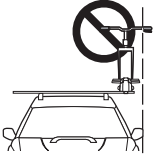

Mount the attachment to prevent the bicycle handle from sticking out of the vehicle width when loading.



Check the height of the loaded bicycle before driving the vehicle. Do not enter a parking lot or tunnel whose ceiling is lower than the loaded bicycle height.



Always lock the key when loading.

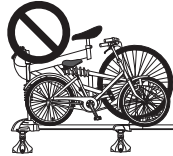

Do not load a bicycle that does not conform with this product. Do not load 2 or more bicycles on one attachment.



Do not use the bicycle container case or a waterproof sheet when loading.



Maintain the speed limit. Slow down in strong winds or when on rough roads.



Due to wind pressure or vibrations as a result of driving the vehicle continuously at speeds in excess of the legal limit, in strong winds, or on rough roads, the knob, the nut, or the bolt may become loose causing the attachment or load to fall involving the vehicle behind or people in an accident.



Remove the carrier before using an automatic car wash. Should the car mistakenly be washed by an automatic car wash with the carrier attached, be sure to inspect the carrier.

## Assembling Product

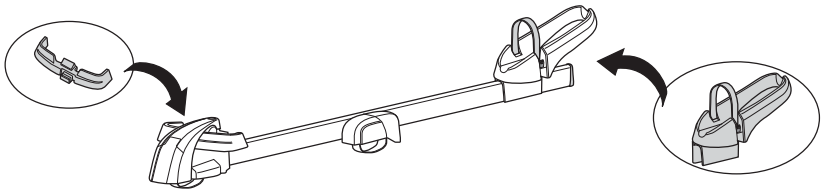

### 1 QR (quick release) assembly

①Unlock the lock, ②**Strongly** push down the QR guard until clicks, and ③turn the QR guard over.

①

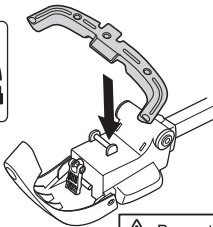

②

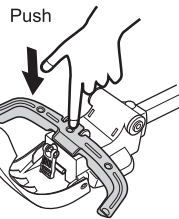

③

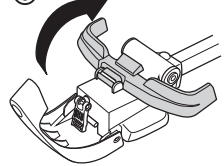

⚠ Precautions

If the QR guard gets stuck in the course of turning over the QR guard, redo the assembly.

## 2 Cradle assembly

① While pressing the lock section on the bottom, ② remove the end cap. ③ Mount the cradle. ④ Attach the end cap.

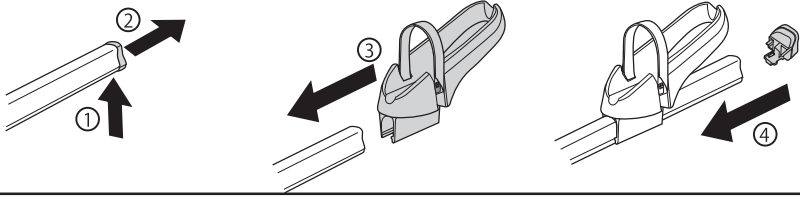

## 3 Swapping the rear attaching portion

The rear attaching portion can be set to either left or right side of the main body. Taking the mounting position on the vehicle into consideration, swap them if necessary.

① ② Remove the end cap, ③ loosen the knob, and ④ ⑤ ⑥ ⑦ swap the rear attaching portions.

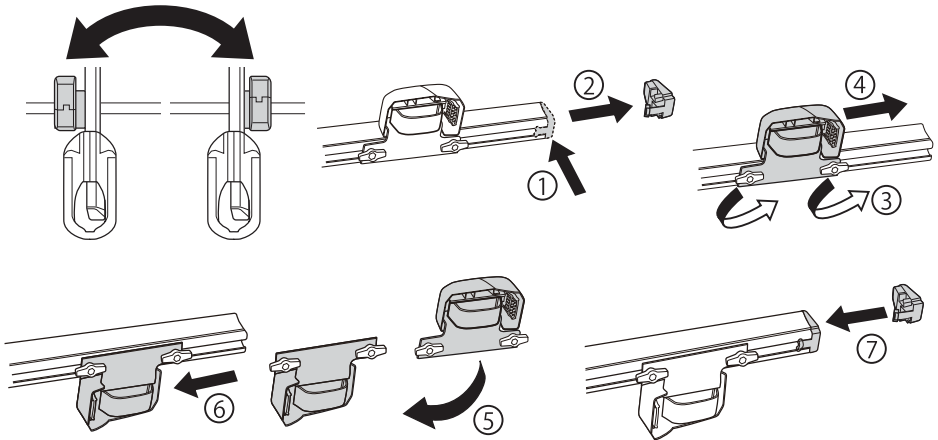

## Installation

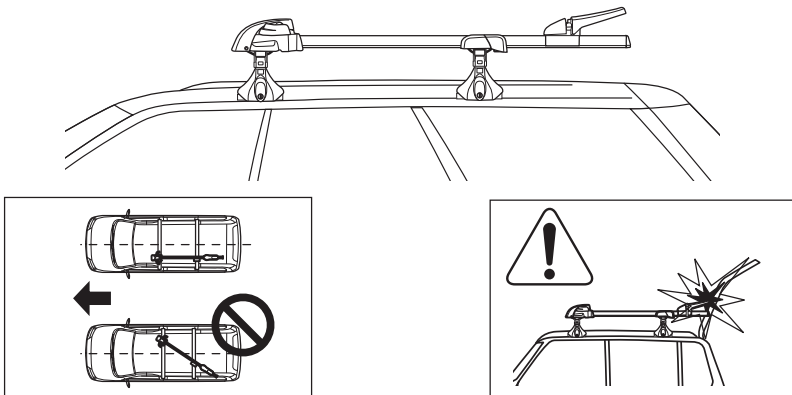

- 1** With the front cover A open, open the front cover B.

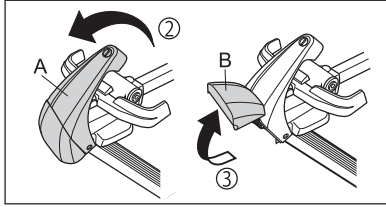
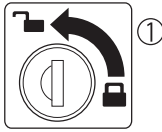

- 2** Align the ▼ mark on the front part with the basic carrier center to mount.

①Bring the belt around the base bar, ②hook it to the hook, and ③tighten the knob. ④Close the front cover B and ⑤the front cover A.

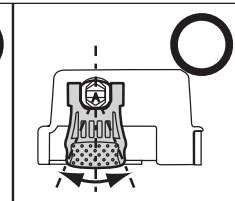
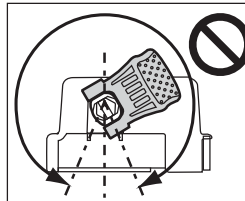
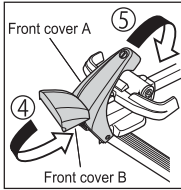
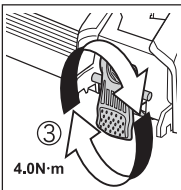
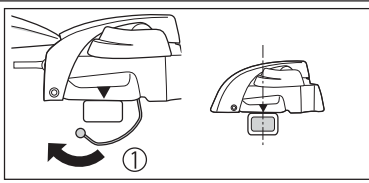
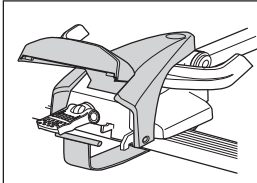

The mounting portion fits in the area causing an initial looseness. Check for any looseness before driving the vehicle. Additionally, tighten any loose sections as necessary.

- 3** ①Align the rear mounting portion with the base bar center, and ②tighten the knob in 2 places. ③Open the cover, and ④bring the belt around the base bar to hook to the hook. ⑤Tighten the knob and ⑥close the cover.

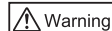
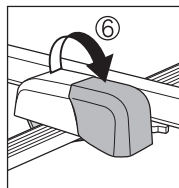
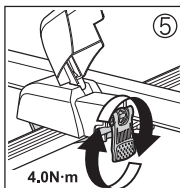
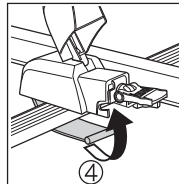
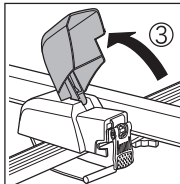
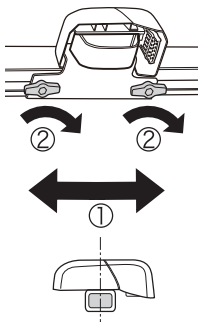

The mounting portion fits in the area causing an initial looseness. Check for any looseness before driving the vehicle, additionally tighten any loose sections as necessary.

## Installation check

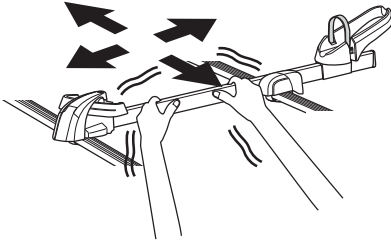

- Shake this product to the front, rear, right, and left direction to confirm that there is no rattling. If any rattling is found, additionally tighten it.
- Check that it is installed parallel to vehicle's advancing direction.
- Check that the center of the mounting portion aligns with the base carrier center.

## Load procedure

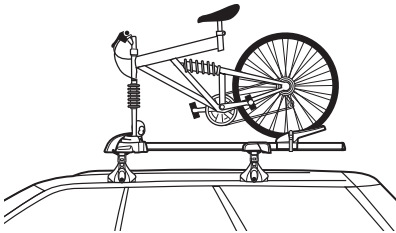

Load and unload a bicycle in a stable and flat place.



When installing, check the installation instructions for the bicycle.

- 1** Choose the correct adaptor which fits the corresponding bicycle to load. (① While pressing the button on the main unit, ② attach and detach the adaptor.)

**9mm 12mm 15mm 20mm**

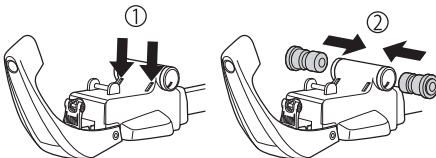

**9mm**



**12mm**

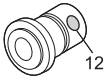

**15mm**

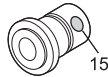

**15mm**

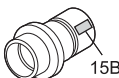

**20mm**

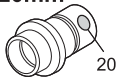

<9mm> Mount the quick lever ASSY.

**9mm**

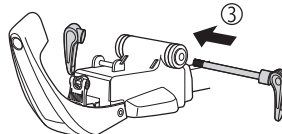
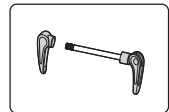

**2****9mm**

Mount the front fork. ① Turn QR guard over, and ② set the front fork to the shaft ③ Adjust the width with the quick lever screw, and turn the quick lever over to fix.

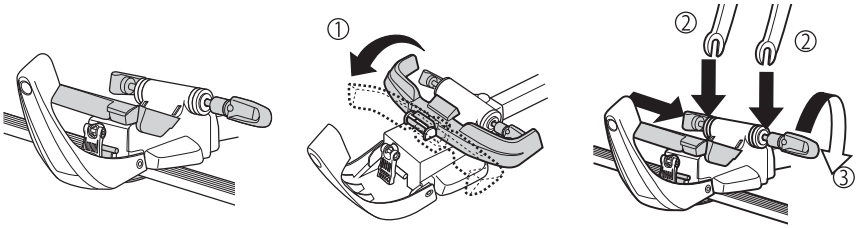
**12mm 15mm 20mm**

This product is to fix a bicycle using the bicycle's thru-axle. For attaching and detaching the thru-axle, tighten it at a designated torque in accordance with the installation instructions for the bicycle.

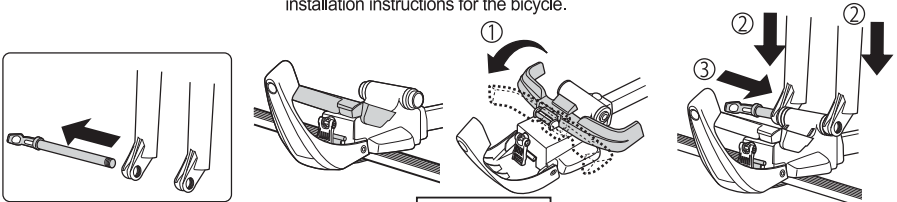

**Precautions**

When loading, make sure that the bicycle does not fall off.

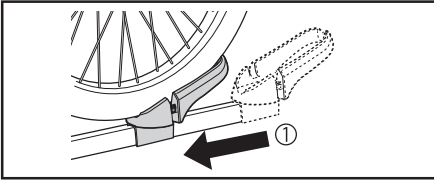
**3**

① Adjust the cradle position in accordance with the tire.

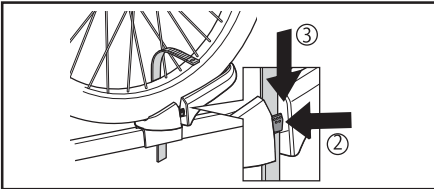
**4**

②③ Fix the tire with the wheel belt.

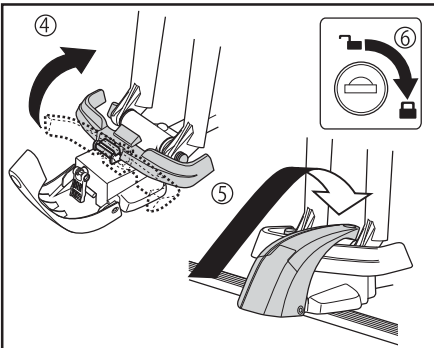
**5**

④ Set the QR guard, ⑤ close the front cover, and ⑥ lock with the key.

## Installation check

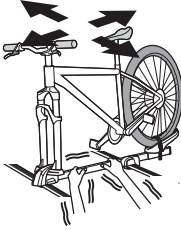

Shake this product to the front, rear, right, and left direction to confirm that there is no rattling in this product and the bicycle. If any rattling is found, additionally tighten it.

## Daily maintenance/how to store

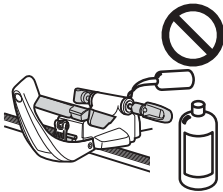

Wash off dirt and mud with water.  
Wipe off dirt with a well wrung-out wet towel.  
Allow it to dry in the shade.

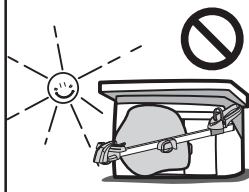

### Storage

Store in a covered, dry location away from sunlight.

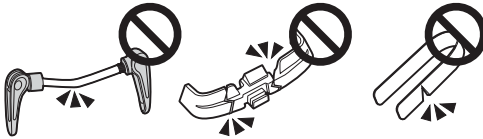

### Inspecting the parts

Clean the parts, and inspect each of the parts for abnormalities. If a deformation or a damage is found, stop using this product and replace with a new one.



## Repair parts

There are genuine spare parts for this product as shown below. Please specify part name when ordering repair parts.

### Note

Specifications and appearance of the carrier system and genuine replacement parts are subject to change without prior notice in the interest of product improvement.

End cap  
ISP754

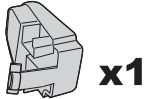

Cradle  
ISP751

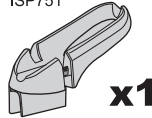

Wheel belt  
ISP975



Quick lever ASSY  
ISP752

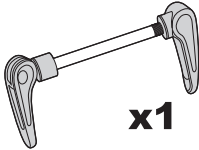

Quick release guard  
ISP753



Key  
※Check the key number.



Adaptor 9mm  
ISP755



Adaptor 12mm  
ISP1149



Adaptor 15mm  
ISP756



Adaptor 15mm  
for boost  
ISP1150

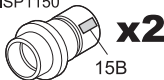

Adaptor 20mm  
ISP757



## Contact Information

We do not accept any liability for accident, damage or injury caused by incorrect installation or use, modification, or natural disaster.

Specifications and appearance of the carrier system and genuine replacement parts are subject to change without prior notice in the interest of product improvement.

**CAR MATE USA, Inc.**  
383 Van Ness Ave., Suite 1603  
Torrance, CA 90501  
support@innoracks.com  
www.innoracks.com

Avant d'utiliser ce produit, veuillez lire attentivement les présentes instructions d'installation pour connaître l'usage correct. Conservez le présent manuel d'instruction dans un endroit sûr. Si vous donnez ce produit à un tiers, fournissez-lui aussi ces instructions pour garantir l'utilisation du système en toute sécurité.

## INA394

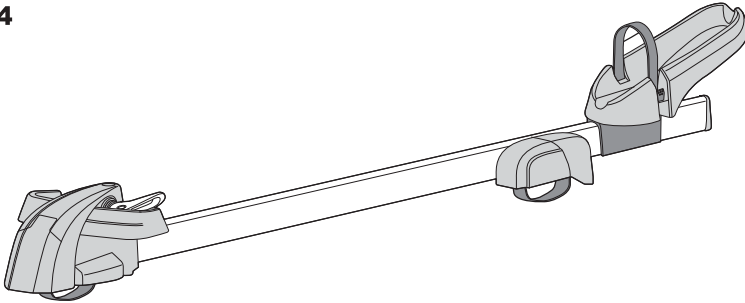

### ⚠ Avertissement

En cas de non-respect de cet avertissement, des accidents graves, entraînant des blessures graves ou mortelles, pourraient se produire.

- Vérifiez la stabilité et la résistance de la base de porte-bagages sur laquelle ce produit doit être installé, et fixez-la solidement.
- Réglez les espaces avant et arrière du porte-bagages de base entre 23.6" et 43.0" (600 à 1100 mm).
- Assurez-vous que le bouton est bien serré avant de conduire le véhicule.
- Ne modifiez pas ce produit.
- Ne chargez pas un vélo qui n'est pas conforme à ce produit. Ne chargez pas 2 vélos ou plus sur une même fixation.
- Conduisez prudemment, en particulier lorsque le porte-bagages est chargé.
- Verrouillez soigneusement lorsque vous conduisez.

### ⚠ Précautions

Le non-respect des précautions peut entraîner des blessures, ou encore endommager le produit, le véhicule ou la charge.

- Ce produit n'est pas protégé contre le vol. Ne laissez pas de charges sur le porte-bagages pendant plusieurs heures.

## Contenu du produit

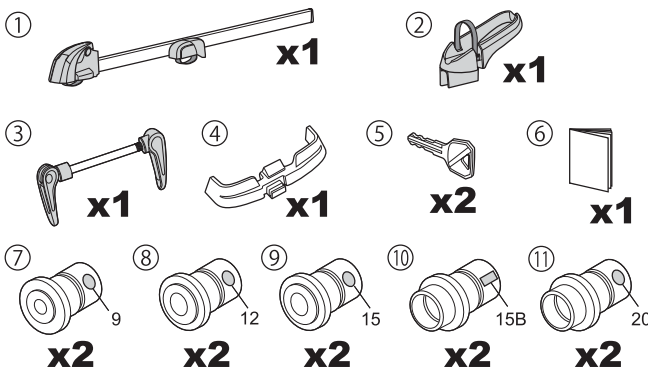

NO.	Éléments
①	Élément principal
②	Berceau
③	Levier rapide ASSY
④	Dispositif de protection à dégageement rapide
⑤	Clé
⑥	Instructions d'installation
⑦	Adaptateur Φ9mmx100
⑧	Adaptateur Φ12mmx100
⑨	Adaptateur Φ15mmx100
⑩	Adaptateur Φ15mmx110
⑪	Adaptateur Φ20mmx110

## Vérification avant usage

Ce produit peut être fixé à la barre de base INNO et au porte-bagages de base d'origine du véhicule (type carré/barre transversale). Pour le fixer au porte-bagages de base, installez-le soigneusement en respectant les instructions d'installation, Instructions.

- Dimensions de la barre transversale (Porte-bagages de base d'origine du véhicule)

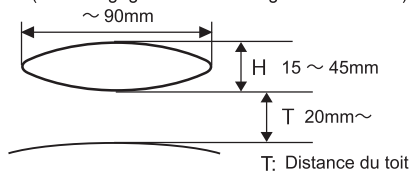

- Largeur de montage requise

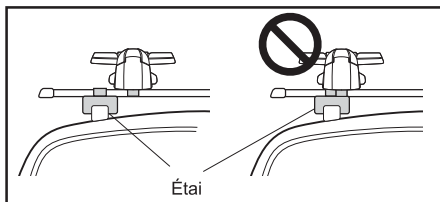
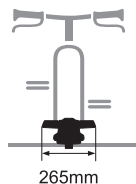

### ⚠ Avertissement

Confirmez la stabilité et la robustesse du système de transport de base sur lequel ce produit doit être installé, et fixez-le fermement.

Si la robustesse du porte-bagages n'est pas suffisante, ne l'installez pas.

Il ne peut pas être monté par-dessus l'étais.

## Vélo conforme

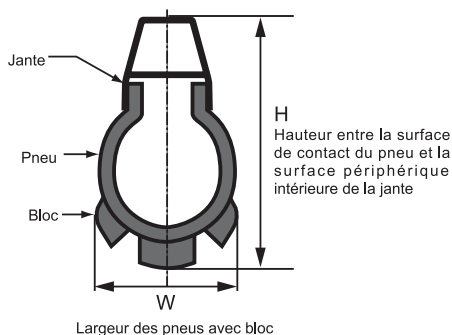

- Type de moyeu avant  
Dégagement rapide :  $\Phi 9\text{mm}$   
Axe traversant :  $\Phi 12 \times 100\text{mm}$ ,  $\Phi 15 \times 100\text{mm}$ ,  
 $\Phi 15 \times 110\text{mm}$ ,  $\Phi 20 \times 110\text{mm}$

- Longueur de l'empattement :  $\sim 1300\text{mm}$

- Dimensions des pneus / jantes arrière  
W:  $\sim 2,8$  po (72mm)  
H:  $\sim 85\text{mm}$

## ⚠ Avertissement

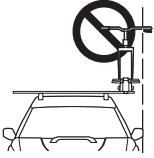

Montez la fixation pour éviter que la poignée de vélo ne dépasse de la largeur du véhicule lors du chargement.



Vérifiez la hauteur du vélo chargé avant de conduire le véhicule. N'entrez pas dans un parking ou un tunnel dont le plafond est plus bas que la hauteur du vélo chargé.



Verrouillez toujours la clé lors du chargement.

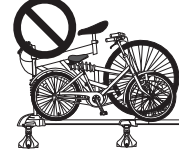

Ne chargez pas un vélo qui n'est pas conforme à ce produit. Ne chargez pas 2 vélos ou plus sur une même fixation.



N'utilisez pas de porte-vélo ou de bâche étanche lors du chargement.



En raison de la pression du vent ou des vibrations provoquées par la conduite prolongée du véhicule à des vitesses supérieures à la limitation autorisée, par des vents violents ou sur des routes accidentées, le bouton, l'écrou ou le boulon peut se desserrer, provoquant la chute de la fixation ou de la charge et mettant en danger le véhicule à l'arrière ou des personnes.



Retirer le porte-bagages avant de passer la voiture au poste de lavage automatique. Si la voiture devait accidentellement passer au poste de lavage automatique avec le système de transport monté, assurez-vous d'inspecter le système de transport.

## Assemblage du produit

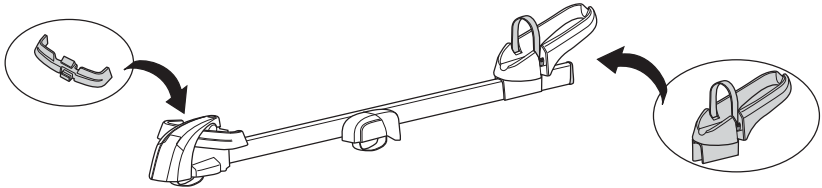

### 1 Assemblage QR (dégagement rapide)

① Déverrouillez le verrou, ② Poussez **fermement** le dispositif de protection QR jusqu'à ce qu'un déclic se fasse entendre, puis ③ retournez le dispositif de protection QR.

①

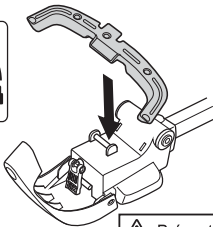

②

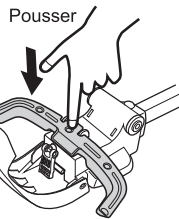

③

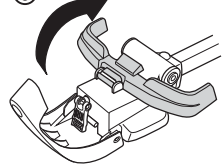

⚠ Précautions

Si le dispositif de protection QR se bloque lorsque vous le retournez, effectuez à nouveau l'assemblage.

## 2 Assemblage du berceau

① Tout en appuyant sur la section de verrouillage sur la partie inférieure, ② retirez le capuchon d'extrémité. ③ Montez le berceau. ④ Fixez le capuchon d'extrémité.

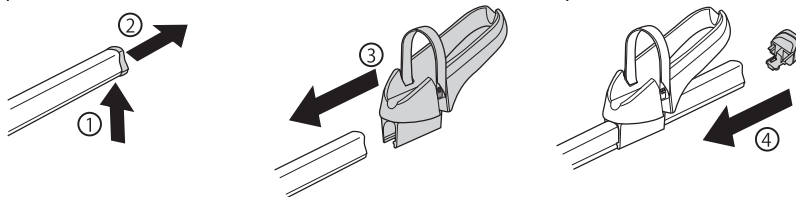

## 3 Intervertir la partie de fixation arrière

La partie de fixation arrière peut être placée à gauche ou à droite du corps principal. En tenant compte de la position de montage sur le véhicule, intervertissez sa position si nécessaire.

① ② Retirez le capuchon d'extrémité, ③ desserrez le bouton, puis ④ ⑤ ⑥ ⑦ intervertissez les parties de fixation arrière.

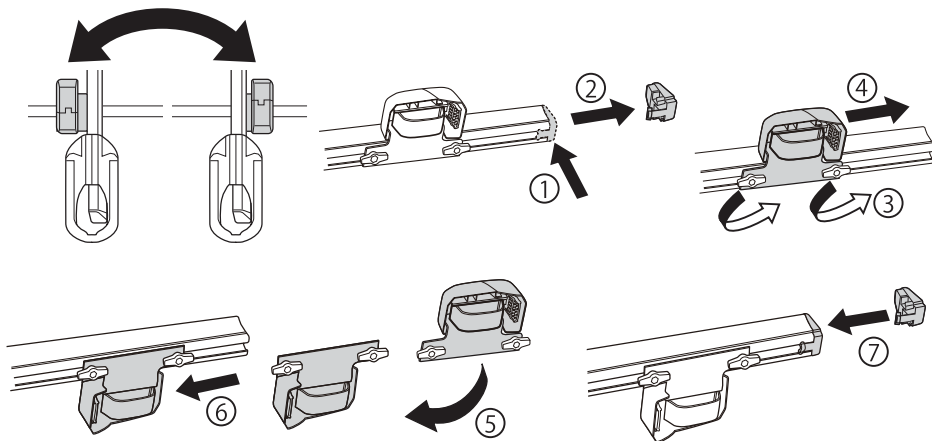

## Installation

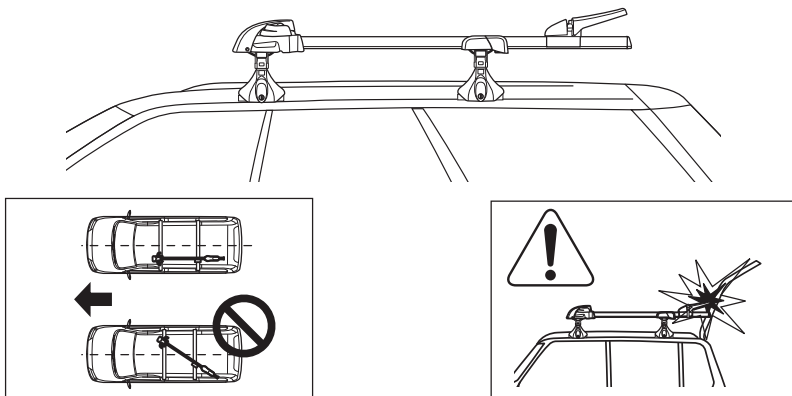

**1** Tout en gardant le couvercle avant A ouvert, ouvrez le couvercle avant B.

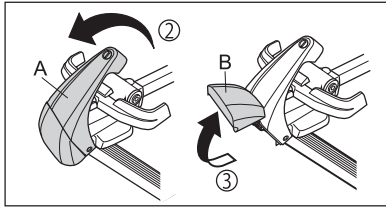
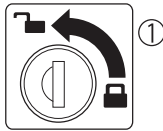

**2** Alignez le symbole ▼ sur la partie avant avec le centre du porte-bagages de base à monter.  
 ①Faites passer la sangle autour de la barre de base, ②accrochez-la au crochet, puis ③serrez le bouton. ④Fermez le couvercle avant B et ⑤le couvercle avant A.

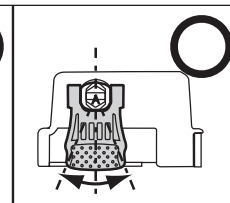
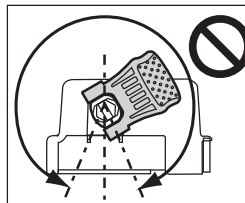
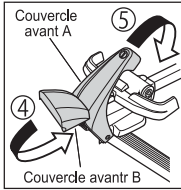
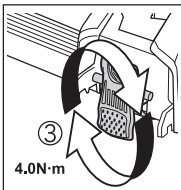
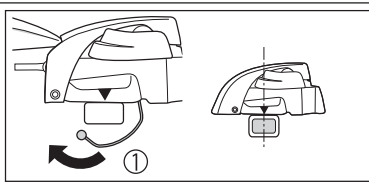
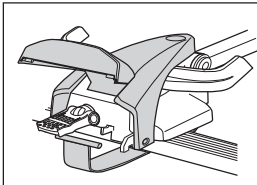

**⚠ Avertissement**

La partie de montage s'insère dans l'espace, provoquant un premier desserrement. Vérifiez la présence d'un éventuel desserrement avant de conduire le véhicule. Ensuite, resserrez toutes les sections desserrées si nécessaire.

**3** ①Alignez la partie de montage arrière avec le centre de la barre de base, puis ②serrez le bouton à 2 emplacements. ③Ouvrez le couvercle, puis ④faites passer la sangle autour de la barre de base pour l'accrocher au crochet. ⑤Serrez le bouton et ⑥fermez le couvercle.

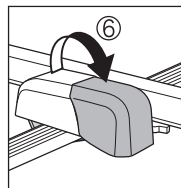
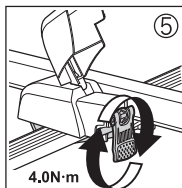
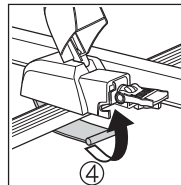
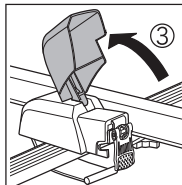
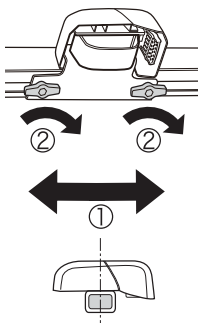

**⚠ Avertissement**

La partie de montage s'insère dans l'espace, provoquant un premier desserrement. Vérifiez la présence d'un éventuel desserrement avant de conduire le véhicule, puis resserrez toutes les sections desserrées si nécessaire.

## Vérification de l'installation

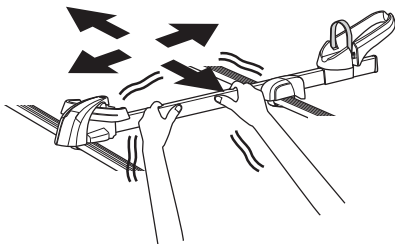

- Secouez ce produit vers l'avant, l'arrière, la droite et la gauche pour vérifier qu'il n'y a pas de battement.
- Si vous constatez un battement, resserrez-le. Vérifiez qu'il est installé parallèlement au sens de marche du véhicule.
- Vérifiez que le centre de la partie de montage est aligné avec le centre du porte-bagages de base.

## Procédure de chargement

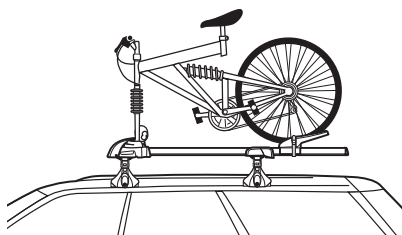

Chargez et déchargez un vélo dans un endroit stable et plat.



Lors de l'installation, consultez les instructions d'installation du vélo.

- 1** Fixez un adaptateur qui s'adapte au vélo à charger.  
 (① Tout en appuyant sur le bouton de l'élément principal, ② fixez et détachez l'adaptateur.

**9mm 12mm 15mm 20mm**

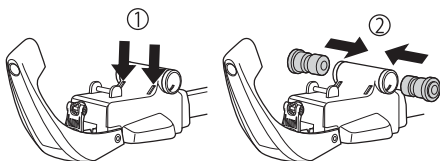

**9mm**



**12mm**

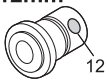

**15mm**



**15mm**

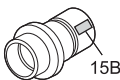

**20mm**

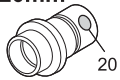

<9mm> Montez le levier rapide ASSY.

**9mm**

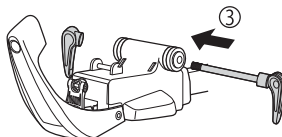
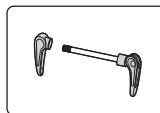

**2****9mm**

Montez la fourche avant. ①Retournez le dispositif de protection QR, puis ②placez la fourche avant sur l'arbre. ③Réglez la largeur avec la vis du levier rapide, puis retournez le levier rapide pour le fixer.

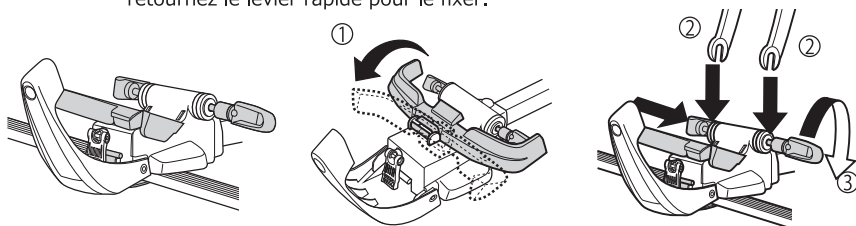
**12mm 15mm 20mm**

Ce produit sert à fixer un vélo à l'aide de l'axe traversant du vélo. Pour fixer et détacher l'axe traversant, serrez-le à un couple spécifique en respectant les instructions d'installation du vélo.

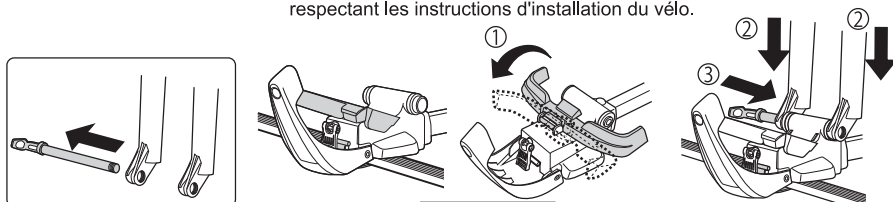

**⚠ Précautions**

Lors du chargement, veillez à ce que le vélo ne se détache pas.

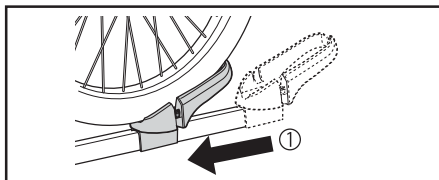
**3**

① Réglez la position du berceau en fonction du pneu.

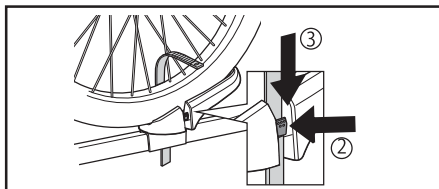
**4**

②③ Fixez le pneu à l'aide de la sangle de roue.

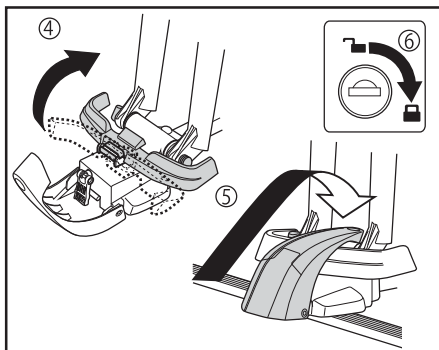
**5**

④ Placez le dispositif de protection QR,  
⑤ fermez le couvercle avant, puis  
⑥ verrouillez à l'aide de la clé.



## Vérification de l'installation

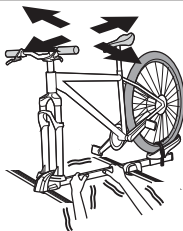

Secouez ce produit vers l'avant, l'arrière, la droite et la gauche pour vérifier qu'il n'y a pas de battement au niveau de ce produit et du vélo. Si vous constatez un battement, resserrez-le.

## Entretien quotidien / stockage

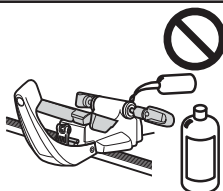

Nettoyez la saleté et la boue à l' eau. Essuyez la saleté à l' aide d' une serviette humide bien essorée. Laissez le produit sécher à l' ombre.

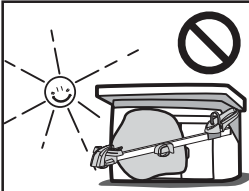

### Soins et rangement

Rangez-le dans un emplacement couvert, sec et sombre.

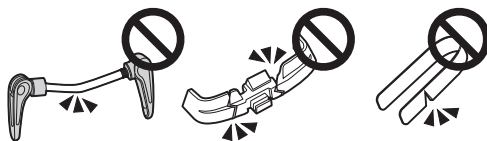

### Inspection des pièces

Nettoyez les pièces et vérifiez qu' aucune d' elles ne comporte de défaut. En cas de déformation ou de dommage, cessez d' utiliser ce produit et remplacez-le par un neuf.

## Pièces de réparation

Il existe des pièces de rechange d'origine pour ce produit, comme indiqué ci-dessous.  
Veuillez préciser le nom des pièces lorsque vous commandez des pièces de réparation.

### Remarque

Les spécifications et l'apparence du dispositif de support et des pièces de rechange authentiques sont sujettes à modification sans préavis pour fin d'amélioration du produit.

Capuchon d'extrémité  
ISP754

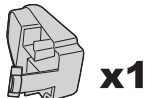

Berceau  
ISP751

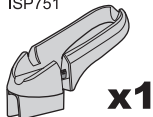

Sangle de roue  
ISP975



Levier rapide ASSY  
ISP752

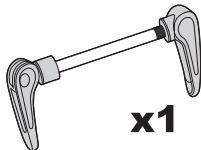

Dispositif de protection  
à dégagement rapide  
ISP753

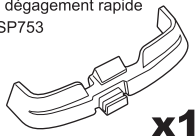

Cié  
※Vérifiez le numéro de la clé.



Adaptateur 9mm  
ISP755



Adaptateur 12mm  
ISP1149



Adaptateur 15mm  
ISP756



Adaptateur 15mm  
Pour le format Boost  
ISP1150

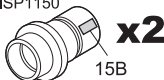

Adaptateur 20mm  
ISP757



## Coordonnées

Nous ne pouvons être tenus responsables d'accidents, de dommages ou de blessures provoqués par une installation ou un usage incorrect, par une modification du dispositif ou par une catastrophe naturelle. Les spécifications et l'apparence du dispositif de support et des pièces de rechange authentiques sont sujettes à modification sans préavis pour fin d'amélioration du produit.

**CAR MATE USA, Inc.**  
383 Van Ness Ave., Suite 1603  
Torrance, CA 90501  
support@innoracks.com  
www.innoracks.com

Antes de utilizar este producto, lea detenidamente estas instrucciones de instalación para usarlo de manera adecuada.  
 Guarde este manual de instrucciones en un lugar seguro. Si le entregara este producto a un tercero, también proporcione estas instrucciones para garantizar un uso seguro.

## INA394

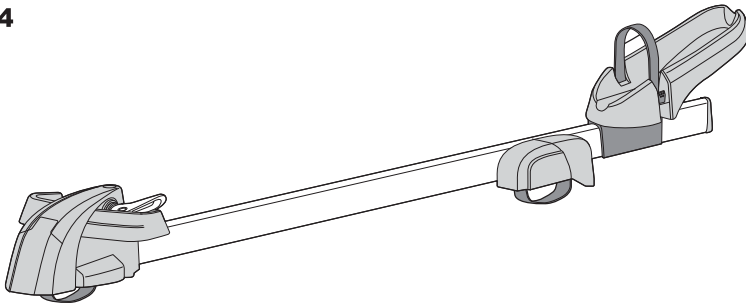

### ⚠ Advertencia

El no respetar esta advertencia puede ocasionar accidentes graves, incluso la muerte o heridas graves.

- Confirme la estabilidad y resistencia de la base del portacargas donde se instalará este producto y fíjelo de manera segura.
- Ajuste el espacio delantero y trasero de la base del portacargas entre 23.6" y 43.0" (600-1100mm).
- Confirme que la perilla está apretada con firmeza antes de conducir el vehículo.
- No haga alteraciones en este producto.
- No debe cargar una bicicleta que no se ajuste a este producto. No debe cargar dos o más bicicletas en un solo aditamento.
- Conduzca con precaución, especialmente cuando el bastidor está cargado.
- Bloquee en forma segura mientras conduce.

### ⚠ Precauciones

Si no tiene estas precauciones, pueden producirse heridas, daños al producto, al vehículo o a la carga.

- Este producto no es antirrobo. No deje cargas durante horas en el bastidor.

## Contenido del producto

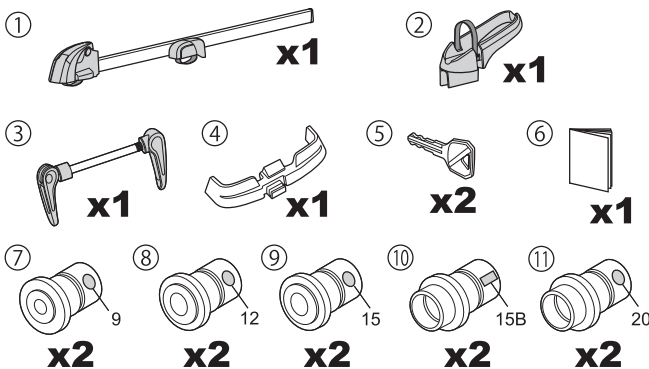

NO.	Piezas
①	Unidad principal
②	Base
③	Palanca rápida ASSY
④	Protector de liberación rápida
⑤	Llave
⑥	Instrucciones de instalación
⑦	Adaptador $\Phi 9\text{mm} \times 100$
⑧	Adaptador $\Phi 12\text{mm} \times 100$
⑨	Adaptador $\Phi 15\text{mm} \times 100$
⑩	Adaptador $\Phi 15\text{mm} \times 110$
⑪	Adaptador $\Phi 20\text{mm} \times 110$

## Verificar antes de usar

Este producto puede fijarse a la barra básica de INNO y al bastidor base original del vehículo (tipo cuadrado/barra transversal). Para fijarlo al bastidor base, instálelo de forma segura de acuerdo con las Instrucciones de instalación.

### ■ Tamaño de encaje de la barra transversal (Bastidor base original del vehículo)

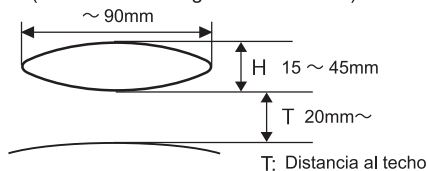

### ■ Ancho de montaje necesario

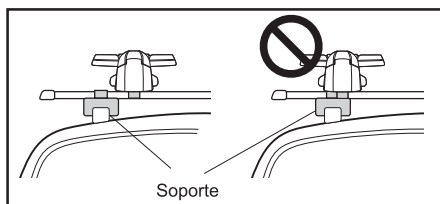
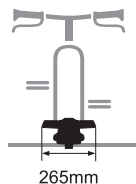

### ⚠ Advertencia

Confirme la estabilidad y la fuerza del portaequipaje de la base en el que se instalará este producto, y ajústelo firmemente.

No lo monte si la resistencia del bastidor base no es suficiente.

No se puede montar pasando por encima del soporte.

## Bicicleta que se ajusta

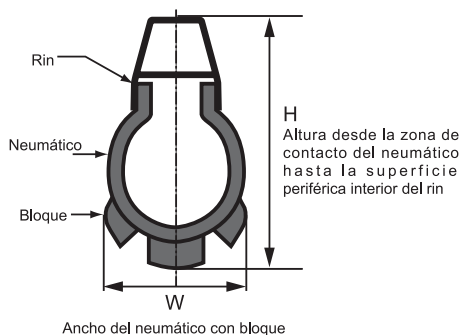

### ■ Tipo de buje delantero

Liberación rápida :  $\Phi 9\text{mm}$

Eje de extensión :  $\Phi 12 \times 100\text{mm}$ ,  $\Phi 15 \times 100\text{mm}$ ,  
 $\Phi 15 \times 110\text{mm}$ ,  $\Phi 20 \times 110\text{mm}$

### ■ Longitud de la distancia entre ejes : ~1300mm

### ■ Tamaño del rin / neumático trasero

W: ~2.8 pulg (72mm)

H: ~85mm

## ⚠ Advertencia

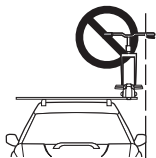

Monte el aditamento para evitar que la manija de la bicicleta sobresalga del ancho del vehículo al cargar.



Verificar la altura de la bicicleta cargada antes de conducir el vehículo. No entre en aparcamientos o túneles cuyo techo sea más bajo que la altura de la bicicleta cargada.



Siempre cierre la llave al cargar.



No debe cargar una bicicleta que no se ajuste a este producto. No debe cargar dos o más bicicletas en un solo aditamento.



No utilice el estuche contenedor de la bicicleta ni ninguna lámina impermeable al cargar.



Mantenga el límite de velocidad. Disminuya la velocidad cuando haya vientos fuertes o cuando conduzca por caminos escabrosos. Debido a la presión del viento o a las vibraciones que resultan de la conducción continuada del vehículo a velocidades que superan el límite legal, en caso de vientos fuertes o de caminos escabrosos, la perilla, la tuerca o el perno pueden soltarse y hacer que el aditamento o la carga se caigan, lo que podría provocar un accidente que implicara al vehículo de detrás o a las personas.



Retire el portaequipaje antes de utilizar un lavadero de autos automático. Si el auto es lavado erróneamente por un lavadero automático con el portaequipaje puesto, asegúrese de inspeccionar el portaequipaje.



## Montaje del producto

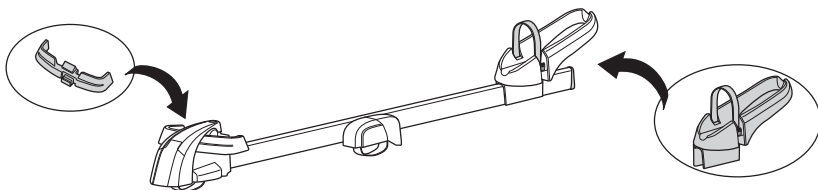

### 1 Ensamblaje de QR (liberación rápida)

- 1 Desbloquee la traba, **empuje fuertemente** hacia abajo el protector de QR hasta que haga clic y
- 3 gire el protector de QR.

1



2 Empuje

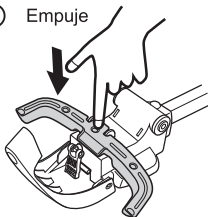

3

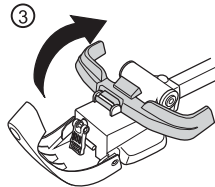

⚠ Precauciones

Si el protector de QR se atasca en el transcurso de su giro, vuelva a realizar el ensamblaje.

## 2 Ensamblaje de la base

① Mientras presiona la sección de bloqueo en la parte inferior, ② retire la tapa del extremo. ③ Monte la base. ④ Coloque la tapa del extremo.

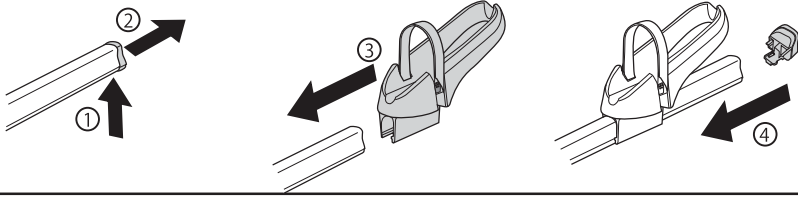

## 3 Intercambio de la parte de aditamento trasera

La parte de aditamento trasera puede ajustarse al lado izquierdo o derecho del cuerpo principal. Si es necesario, cambie la posición de montaje en el vehículo.

① ② Retire la tapa del extremo, ③ afloje la perilla e ④ ⑤ ⑥ ⑦ intercambie las partes de aditamento traseras.

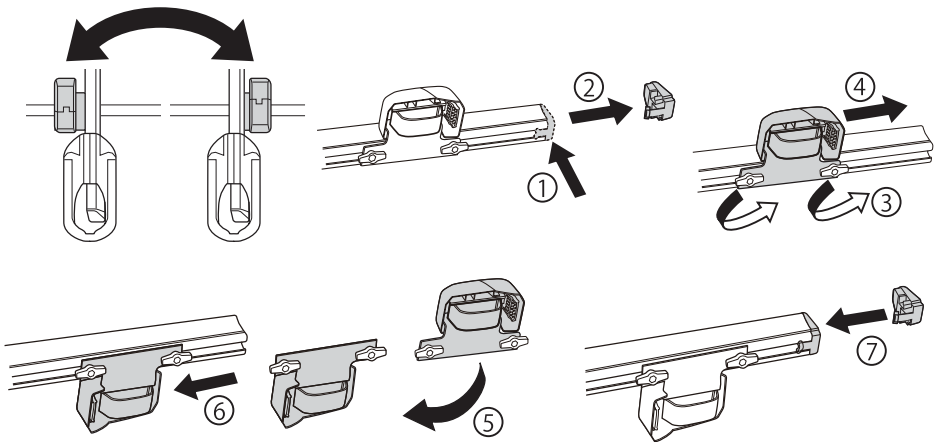

## Instalación

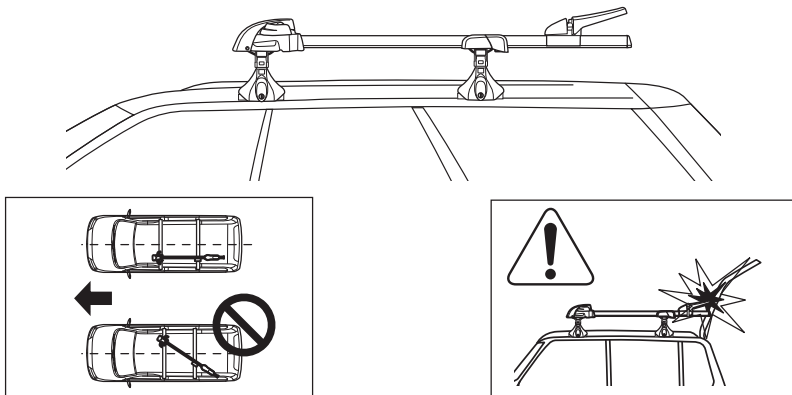

- 1** Con la cubierta delantera "A" abierta, abra la cubierta delantera "B" .

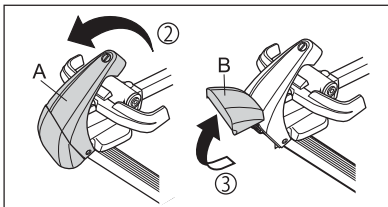
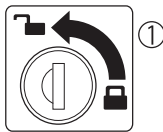

- 2** Alinee la marca ▼ de la parte delantera con el centro del bastidor básico para el montaje.  
 ① Pase la correa alrededor de la barra base, ② engánchela al gancho y ③ apriete la perilla.  
 ④ Cierre la cubierta delantera "B" y ⑤ la cubierta delantera "A" .

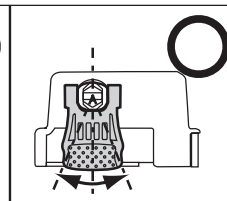
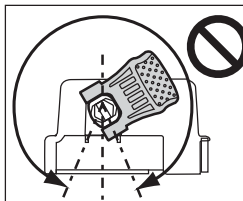
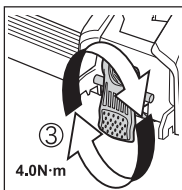
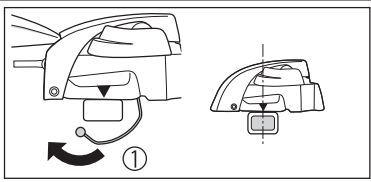
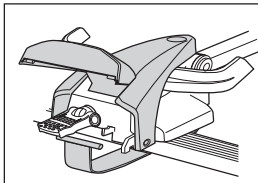

**⚠ Advertencia**

La parte de montaje encaja en la zona, lo que causa cierta holgura inicial. Debe verificar que no haya nada suelto antes de conducir el vehículo. Además, si es necesario, apriete cualquier sección suelta.

- 3** ① Alinee la parte de montaje trasera con el centro de la barra base y ② apriete la perilla en 2 ubicaciones. ③ Abra la cubierta y ④ pase la correa alrededor de la barra base para engancharla al gancho. ⑤ Apriete la perilla y ⑥ cierre la cubierta.

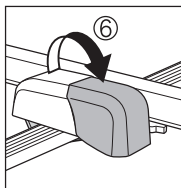
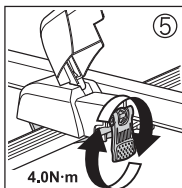
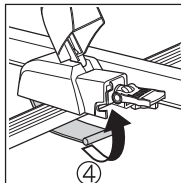
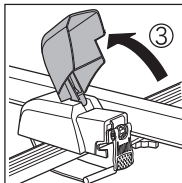
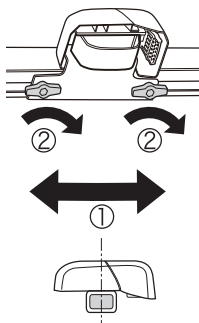

**⚠ Advertencia**

La parte de montaje encaja en la zona, lo que causa cierta holgura inicial. Debe verificar que no haya nada suelto antes de conducir el vehículo y, además apriete cualquier sección suelta si es necesario.

## Revisión de la instalación

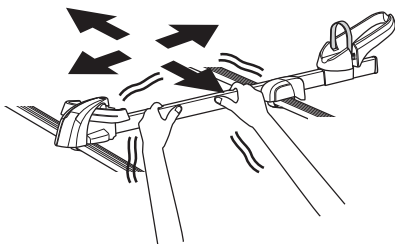

- Agite este producto hacia adelante, atrás, derecha e izquierda para confirmar que no haya traqueteo.
- Si escucha algún traqueteo, apriete más. Debe verificar que está instalado en paralelo a la dirección de avance del vehículo.
- Debe verificar que el centro de la parte de montaje esté alineado con el centro del bastidor base.

## Procedimiento de carga

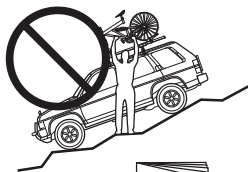
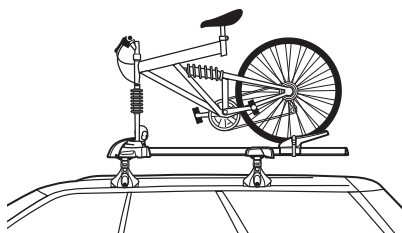

Cargue y descargue la bicicleta en un lugar estable y plano.



Al instalar, debe verificar las instrucciones de instalación de la bicicleta.

- 1** Monte un adaptador que se ajuste a la bicicleta que va a cargar. (① Mientras presiona el botón de la unidad principal, ② fije y desmonte el adaptador).

**9mm 12mm 15mm 20mm**

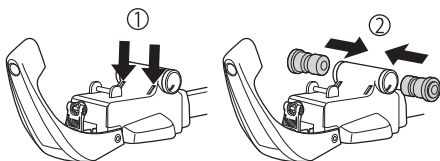

**9mm**



**12mm**

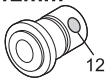

**15mm**

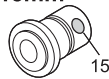

**15mm**

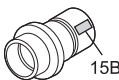

**20mm**



- <9mm> Monte la palanca rápida ASSY.

**9mm**

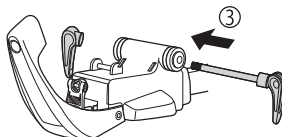
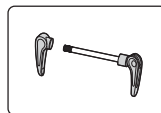



**2****9mm**

Monte la horquilla delantera. ①Gire el protector de QR y ②coloque la horquilla delantera en el eje. ③Ajuste el ancho con el tornillo de la palanca rápida y gire la palanca rápida para fijarla.

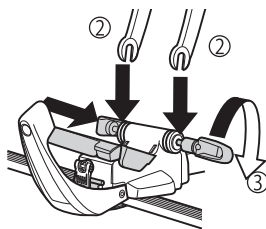
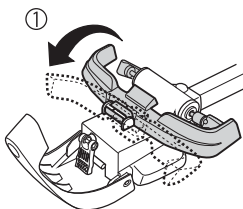
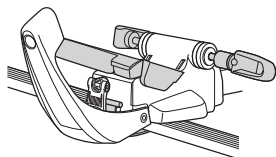
**12mm 15mm 20mm**

Este producto es para fijar una bicicleta utilizando el eje de extensión de la misma. Para fijar y desmontar el eje de extensión, apriételo con un par de torsión apropiado de acuerdo con las instrucciones de instalación de la bicicleta.

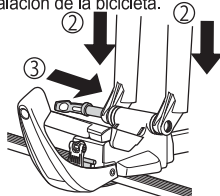
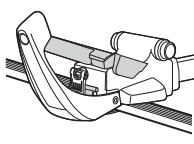
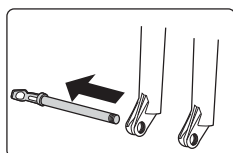

**⚠ Precauciones**

Asegúrese de que la bicicleta no se caiga al cargarla.

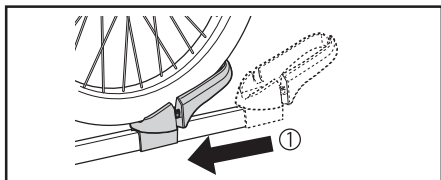
**3**

①Ajuste la posición de la horquilla de acuerdo con el neumático.

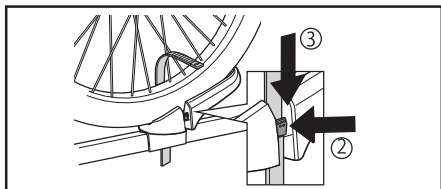
**4**

②③Fije el neumático con la correa de la rueda

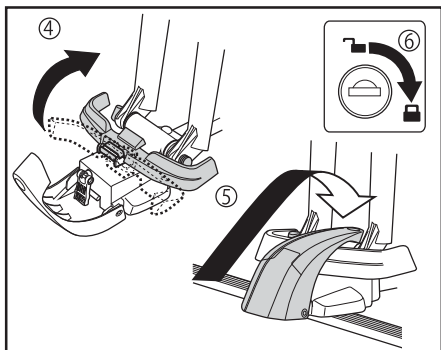
**5**

④Ajuste la protección de QR, ⑤cierre la cubierta frontal y ⑥bloquee con la llave.

## Revisión de la instalación

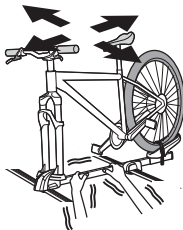

Agite este producto hacia delante, atrás, derecha e izquierda para confirmar que no haya traqueteo en el producto ni en la bicicleta. Si escucha algún traqueteo, apriete más.

## Mantenimiento diario / Cómo se almacena

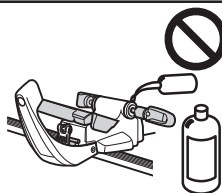

Elimine el polvo y lodo con agua. Limpie la suciedad con una toalla mojada bien estrujada. Deje que se seque a la sombra.

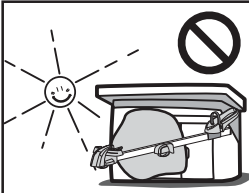

**Cuidado y macenamiento**

Almacene en un lugar cubierto, seco y alejado de la luz del sol.

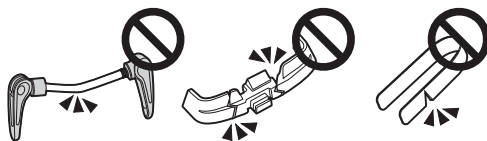

**Cuidado y almacenamiento**

Limpie las piezas e inspeccione cada una de ellas para ver si hay alguna anomalía. Si encuentra alguna deformación o daño, deje de utilizar este producto y sustitúyalo por uno nuevo.

# Piezas de repuesto

Hay repuestos originales para este producto, como se muestra a continuación. Por favor, cuando solicite piezas de repuesto, especifique el nombre de la pieza.

## Nota

Las especificaciones y apariencia del sistema y piezas de repuesto originales del portacargas están sujetas a cambio sin previo aviso en razón de mejora del producto.

Tapa del extremo  
ISP754

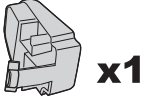

Base  
ISP751

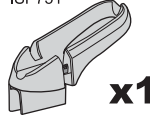

Correa de la rueda  
ISP975



Palanca rápida ASSY  
ISP752

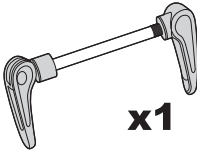

Protector de liberación rápida  
ISP753

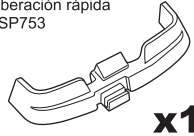

Llave

※Verificar el número de llave.



Adaptador 9mm  
ISP755

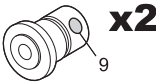

Adaptador 12mm  
ISP1149



Adaptador 15mm  
ISP756



Adaptador 15mm  
Para impulso  
ISP1150

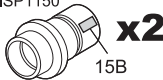

Adaptador 20mm  
ISP757



## Información de contacto

No asumimos ninguna responsabilidad por accidentes, daños u otros perjuicios ocasionados por su incorrecta instalación, uso, modificación o por desastres naturales.

Las especificaciones y apariencia del sistema y piezas de repuesto originales del portacargas están sujetas a cambio sin previo aviso en razón de mejora del producto.

**CAR MATE USA, Inc.**  
383 Van Ness Ave., Suite 1603  
Torrance, CA 90501  
support@innoracks.com  
www.innoracks.com