



IF44 Rod Box Installation Instructions

Before using this product, carefully read this instruction manual for proper use.

Keep this instruction manual in a safe place.

If you are to give this product to a third person, provide him/her with this manual as well to ensure safe use.

IF44

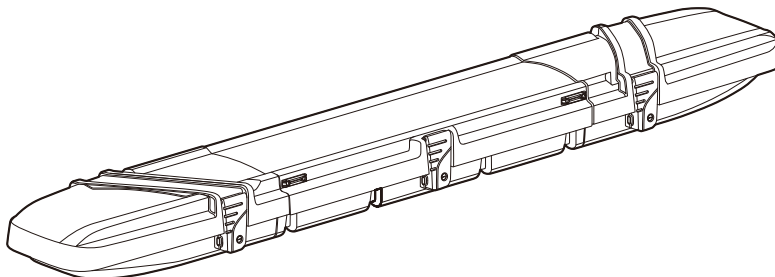

Warning Failure to follow this warning can result in serious accidents including death or serious injury.

- This product is made specifically for fishing rods and those with reels attached.
Do not use for other purposes.
- Do not modify this product.
- Avoid overspeeding, sudden starts, sudden turns, and sudden braking as much as possible.
- Close the cover securely and lock with the key. Failing to do so may cause the cover to open while driving, and the rod box to be damaged and/or to fall off the vehicle roof due to wind pressure.
- Before driving, check the two installation positions with the base carriers, and the bolted positions on the product body are securely tightened. Re-tighten all loosely-bolted positions.

Precautions Failure to follow precautions can result in injury, damage to the product, vehicle, or load.

- Make sure that the vehicle rear hatch (trunk) does not hit the rod box when opening.
- The rod box is not constructed to be completely waterproof.
Loaded items may get wet due to strong rain.
- Opening and closing the rod box during strong gusts or winds may cause the box to be damaged, or have your body trapped in the box, leading to injury.
- Always remember that the vehicle height has increased when the rack is installed.
- Remove the rack before using an automatic car wash.
- Do not use a car cover (including a cover for preventing paint splatter) with this product installed.
The rod box may deform due to weather conditions such as high temperatures.
- Do not place any items on this product. Doing so may cause cover deformation.

Note Before using this product, the followings should be noted.

- The rod box materials gradually deteriorate due to exposure to UV light. If you do not plan to use the rod box for a long period of time, store it away from direct sunlight, high temperature, and high humidity.

Product contents

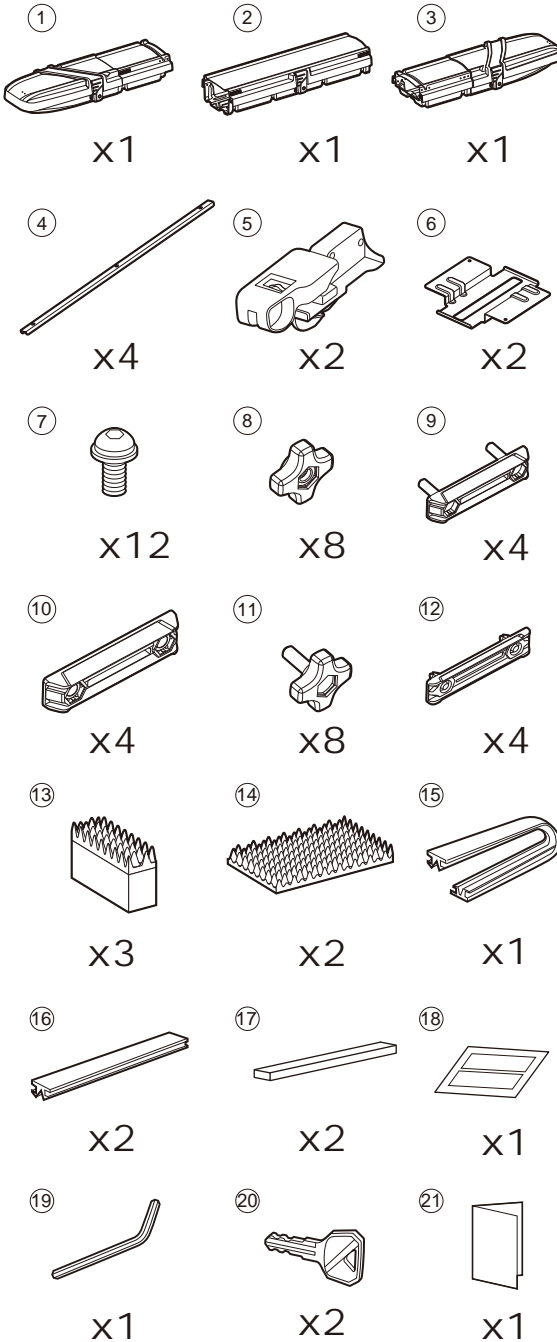

Common parts

No.	Part name
①	Body A (Cover A & Bottom A hinged)
②	Body B (Cover B & Bottom B hinged)
③	Body C (Cover C & Bottom C hinged)
④	Frame
⑤	Memory mount
⑥	Bottom plate
⑦	Hexagonal concave bolt *1
⑧	Knob nut
⑨	Joint bolt
⑩	Joint nut
⑪	Knob bolt
⑫	Filler cap *2
⑬	Grip cushion
⑭	Bottom cushion
⑮	Mold L
⑯	Mold S *2
⑰	Watertight mold *3
⑱	Specification sticker
⑲	Hex Wrench
⑳	Key
㉑	Installation instructions

*1. These bolts are bolted to the frame when the product has shipped. Unbolt them when assembling.

*2. Two Mold Ss and two of these Filler caps are attached to Cover A and Cover C, respectively.

*3. Two Watertight molds are attached to Cover A and Cover C, respectively.

1 Determining a Length

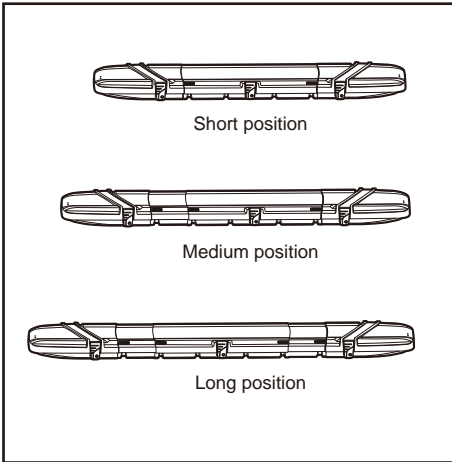

The length of this product can be adjusted at three levels according to your longest rod.

Loadable rod length

Short position 2,200 mm (7' 2")

Medium position 2,480 mm (8' 1")

Long position 2,760 mm (9' 0")

Note

The above lengths are the shortest for each position, as a damper is equipped on the inside of Body A and C. The maximum length of a loadable rod can be extended by about 0.8" (20 mm) depending on how you place the rod.

Note

Do not use the short position if the distance between the base racks is between 32" (810 mm) and 35" (890 mm).

Note

Body A and C are symmetrical. As such, either edge can be considered the front face with regard to moving direction of the vehicle. Install with your opening/closing side facing outward on your vehicle.

2 Assembly of Body A, B and C

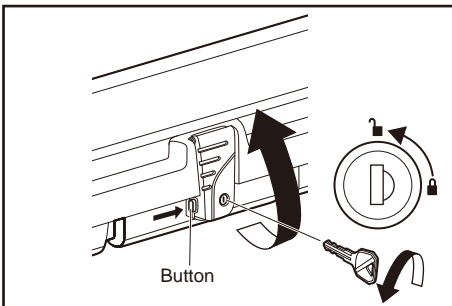

1 Open Cover B

Unlock Cover B with the key as illustrated. Lift the lever while pressing the button.

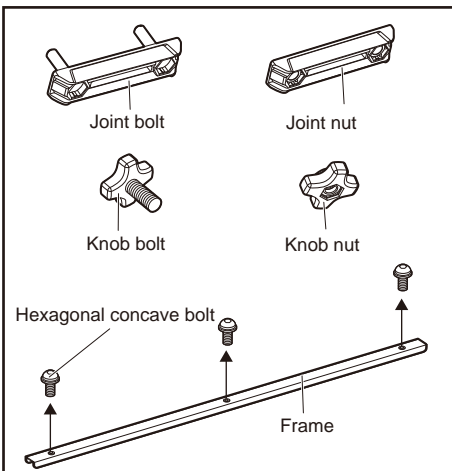

2 Remove all of the joint bolts, the joint nuts, the knob bolts and the knob nuts from the cardboard.

Unbolt all the hexagonal concave bolts from the frame.

Note

To facilitate the further assembly, group these removed parts by type.

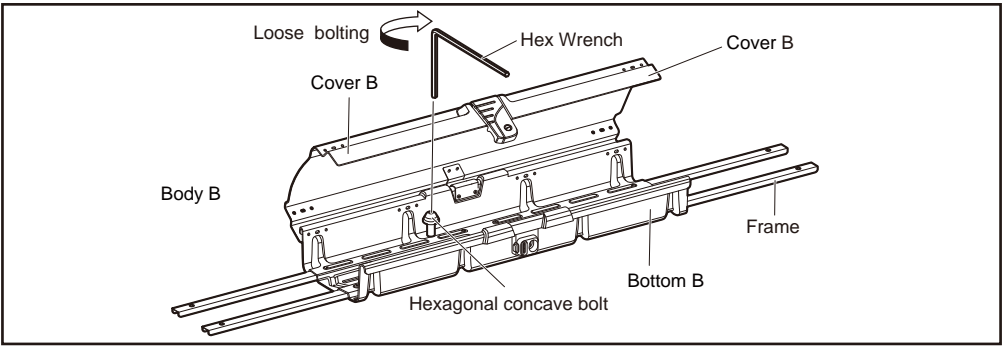

3 Open Cover B. Align the nut on the frame edge with the hole on Bottom B that is proximate to the center. Loosely bolt all of four nut portions with the hexagonal concave bolt.

Note

As Body B is not equipped with a damper between Cover B and Bottom B, Cover B goes freely as far back as to the other side. When opening Cover B, take caution to avoid damage.

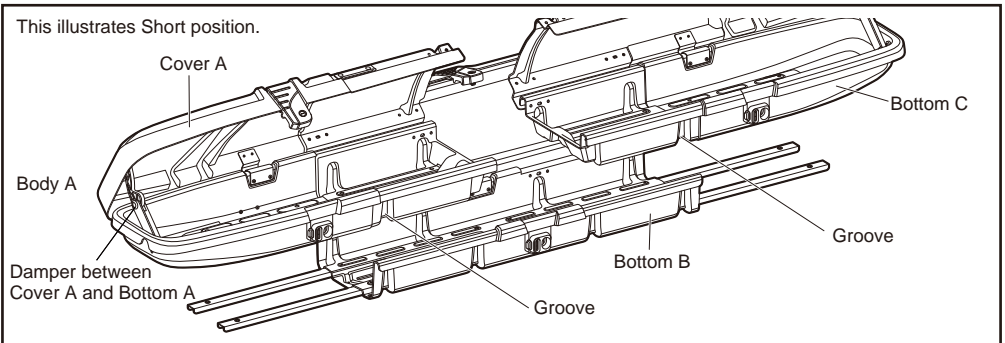

4 Open Cover A and C. Place them on Bottom B in predetermined length positions.

Note

Engage Bottom A and C in the grooves on Bottom B as per each position.
For Medium position, ensure the Body (either A or C) on the vehicle front side is longer than the other on the rear.

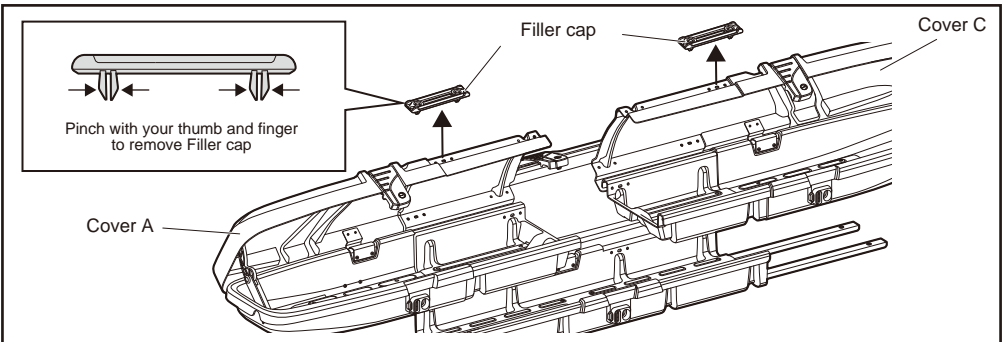

5 Remove the filler caps on Cover A and C as necessary, depending on your position.
 Short position : Remove all the four filler caps from Cover A and C.
 Medium position : Remove the two filler caps from the shorter Cover.^{**1}
 Long position : Keep all the four filler caps on.

^{**1}: Cover C if installed on the left side on the vehicle

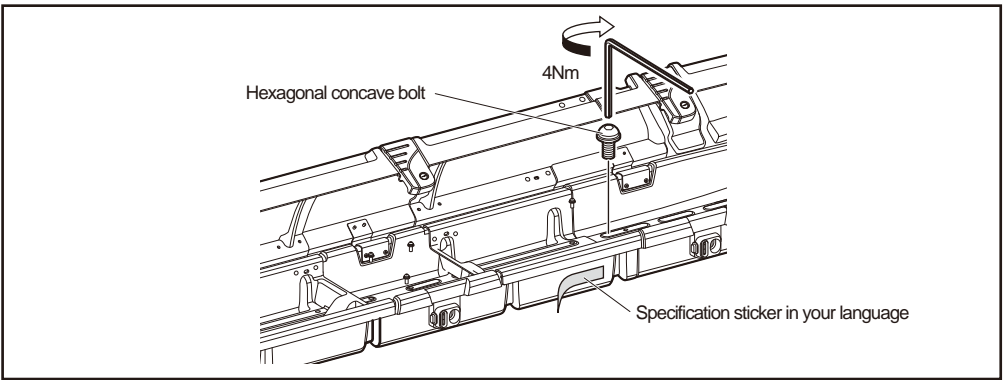

6 Attach the four frames to Bottom A and C by firmly bolting the hexagonal concave bolts in all the 12 locations, holding the longer end of the hex wrench to tighten.(4Nm)

7 Stick the specification sticker described in your language.

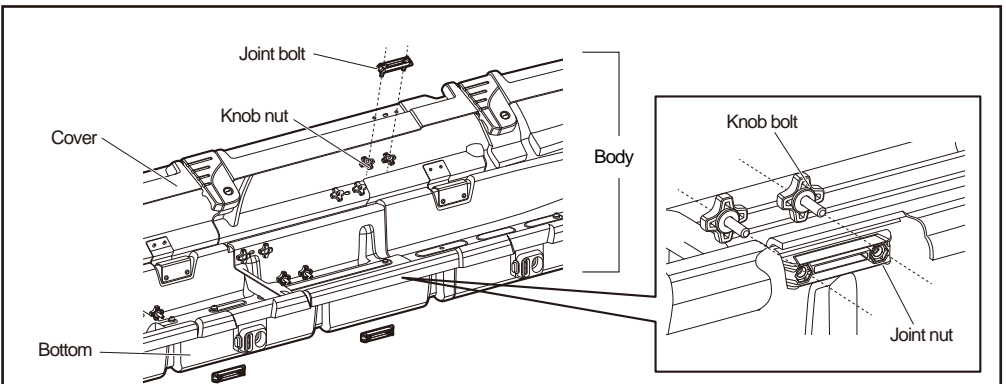

8 Align the hole on the flange portion of Bottom A and C with the convex shape on the joint nut center. Fixate from the inside using the knob bolt.

Note

When assembling each Body, start at the hinged portion to attach the joint nuts and the knob bolts more easily.

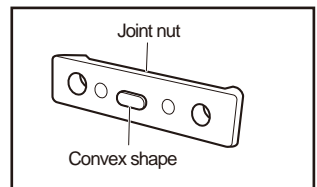

9 Insert the joint bolt from the outside of Cover A and C. Fixate it on the inside with the knob nut to Cover B.

Note

Inserting the bolts may be difficult as the joint nuts and the knob nuts have a rubber washer to prevent loosening. When attaching, turn the knob while pressing it lightly to tighten.

3 Deciding the installation position of the Rod Box

1 Confirm that the base rack is correctly installed, and temporarily place the rod box on the base rack.

2 Open Cover A, B and C. Adjust the position of the product so that the slits are placed on the base rack. If the base rack is adjusted beneath the outer slit, remove the mold S to install.

Distance between the base racks

Short position 24" to 31" / 35" to 55"

Medium position 24" to 67"

Long position 24" to 82"

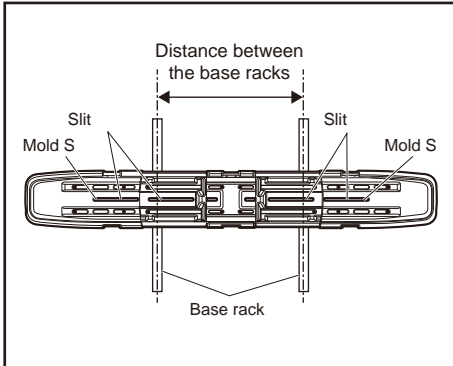

⚠ Precautions

Make sure the distance between the base racks is more than 24" (600 mm).

If the distance is too narrow, too much pressure will be exerted on the rod box, which may cause it to fall off the vehicle.

Note

If adjustable, allow as long a distance as possible between the base racks. A longer distance will stabilize the rod box, and keep the vehicle cross bars under less stress.

⚠ Precautions

Ensure the midpoint of the product is aligned with right between the base racks.

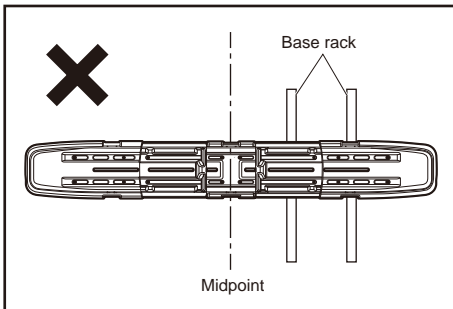

3 Open the vehicle rear hatch to ensure it does not hit the rod box. If it does, change position of either the rod box or the base rack.

Note

Some vehicle types have specific installation positions of the base rack, and touching the rear hatch is unavoidable.

Open the rear hatch carefully not to damage the rod box.

⚠ Precautions

Make sure to install the rod box so that it runs parallel with the direction of the vehicle.

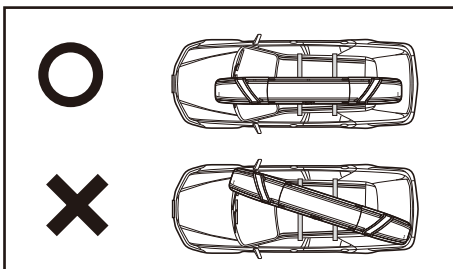
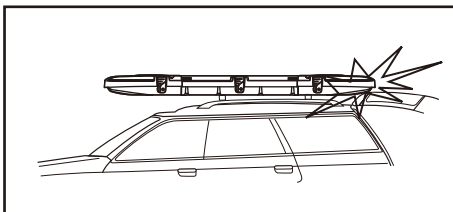

4 Installation of the Rod Box

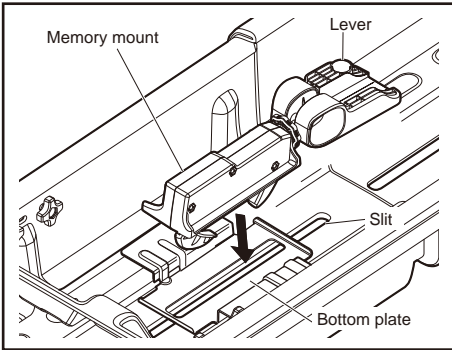

1-1 Place the bottom plate on the slit of the base rack installation portion.

1-2 Lift the lever of the memory mount open. Insert the hooks into the slit so they hold the base bar. The lever can face either direction.

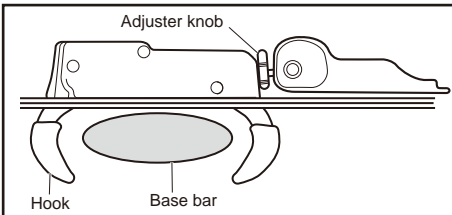

1-3 If the space between the hooks is too small, make the space wider with the adjuster knob.

Note

To facilitate the widening of the space, detach the memory mount from the body.

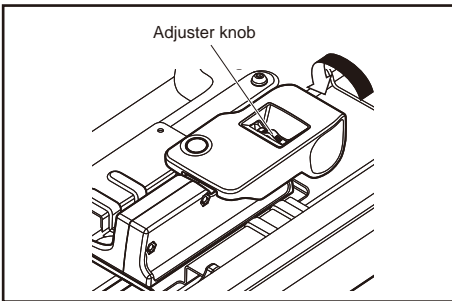

2 Close the lever. Turn the adjuster knob as the arrow indicates (or clockwise) to align the centers of both hooks and the base rack.

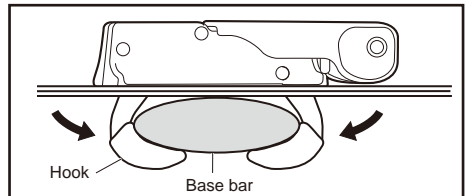

Dimensions of installation hardware

Mountable bar dimensions

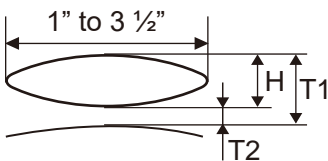

H : $\frac{3}{4}$ " to $1\frac{3}{8}$ "

T1 : Distance to the roof
Allow minimum $2\frac{1}{8}$ "

T2 : Allow minimum 1"

*Cannot be installed onto round bars.

This rod box is mountable onto genuine base racks and crossbars of the vehicle manufacturer, as well as the INNO crossbars. Make sure to install the base rack and/or crossbars securely.

Warning

Check vehicle or base rack product instructions to confirm that the base rack to which this product is to be installed has sufficient strength to support this product. If the base rack does not have sufficient strength to support this product, do not install.

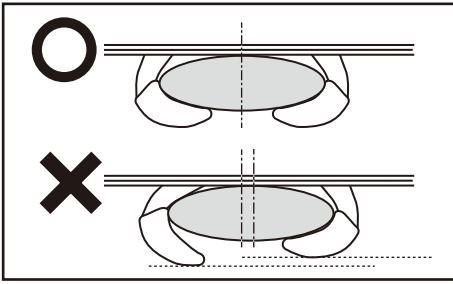

⚠ Precautions

If the height of the 2 hooks differs, the hook center will not match the base bar center.
 Check that hooks are symmetrically positioned.
 The hooks may loosen over time if they are not symmetrically positioned.
 Readjust the adjuster knob to tighten.

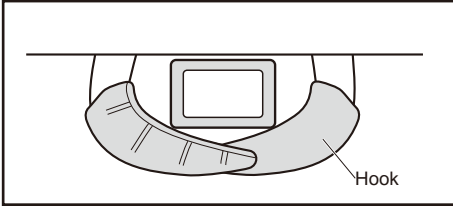

📌 Note

When the square bar is placed, keep the tips of the hooks as close as illustrated.

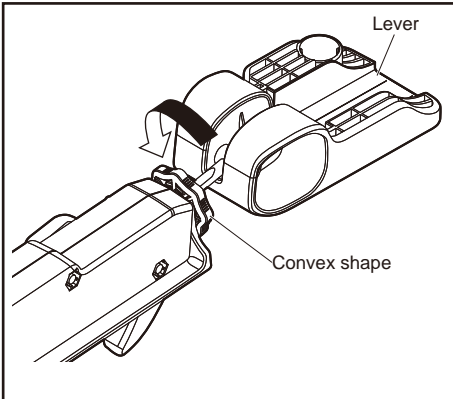

3 Open the lever, and rotate the adjuster knob to the direction indicated by the arrow (counter clockwise) by about 5 turns to make the hook space narrower. Confirm that the base bar center matches the center between hooks, close the lever to securely tighten. If the lever is loose, rotate the adjuster knob more. If the lever is too tight, reverse the direction of the adjuster knob and securely tighten.

📌 Note

*Adjuster knob has a convex shape to indicate how many turns are made.
 *Depending on the shape of the base bar, make more or less turns to tighten the hooks.

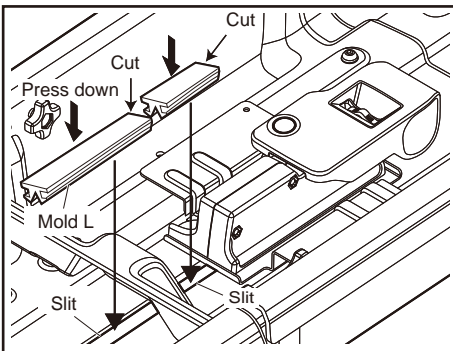

4 Cut the mold L to the length of the open slit. Press down the cut mold L into the open slit to fill it.

📌 Note

Forcefully press down the cut mold L so that its entire upper surface is evenly flat.

5 Loading rods

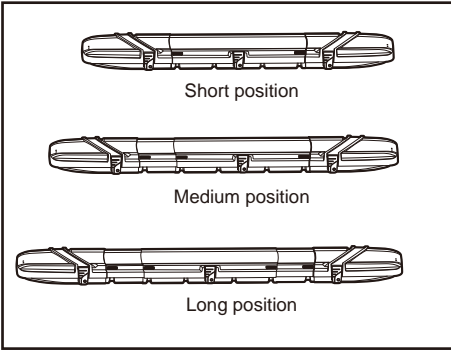

Loadable rod length

Short position 2,200 mm (7' 2")

Medium position 2,480 mm (8' 1")

Long position 2,760 mm (9' 0")

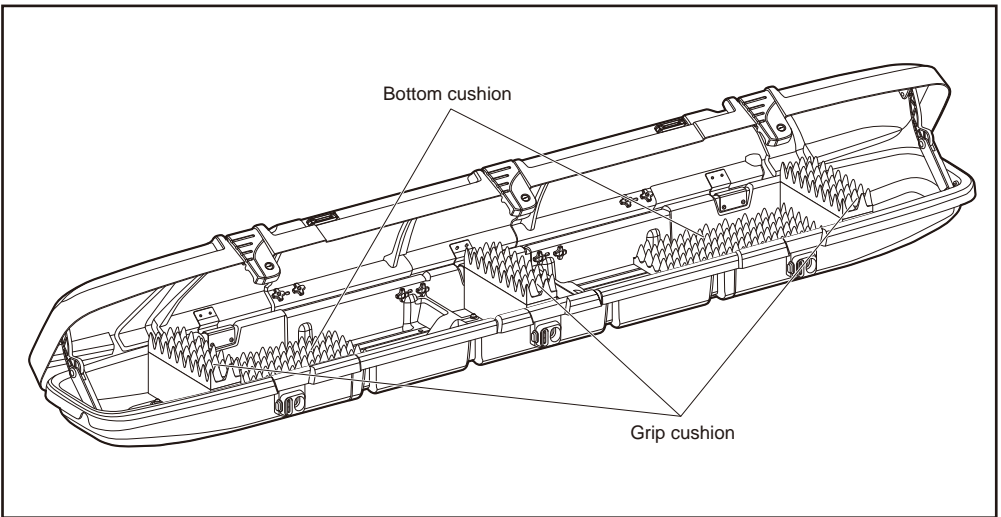

1 Temporarily place the grip cushions and the bottom cushions as illustrated.

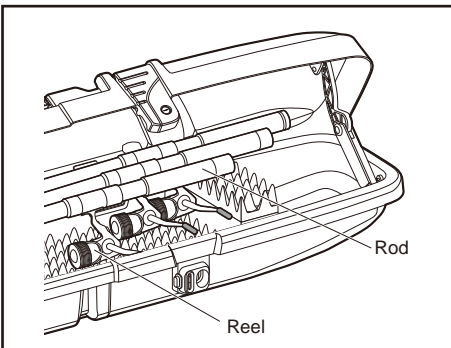

2 Place your rods with their reels attached. Adjust the loading positions of the rods.

Note

Adjust so that the reels are placed on the bottom cushions.

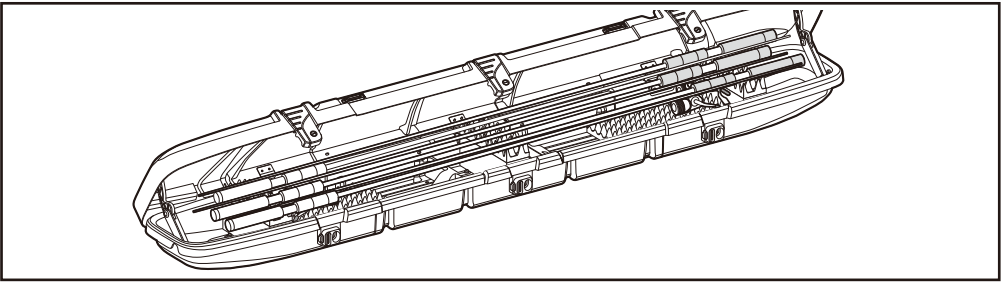

3 When placing multiple rods, alternate the direction of each rod's grip / tip.

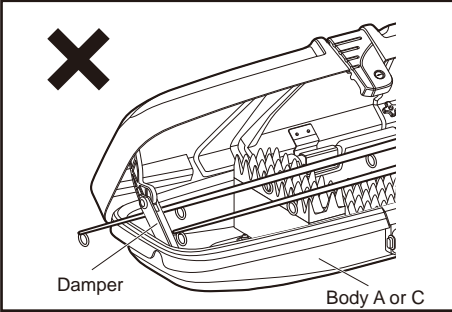

⚠ Precautions

Ensure the tip of the rod does not stick out of the body, or it does not hit the damper.

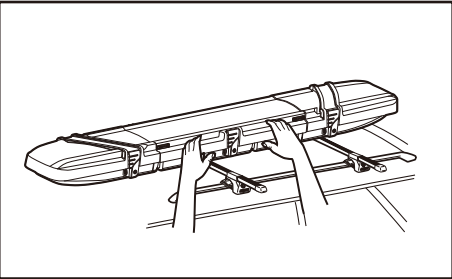

📌 Note

If you have difficulty opening the cover, lift the two portions on the center simultaneously shoulder-width apart.

6 Maximum load capacity

Maximum 22 lbs. (10 kg)

Front	Center	Rear
7.7 lbs.	6.6 lbs.	7.7 lbs.
(3.5 kg)	(3.0 kg)	(3.5 kg)

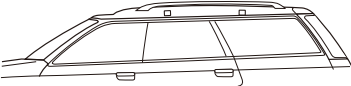

Maximum load capacity : 22 lbs.or 10 kg

⚠ Precautions

Ensure your loads on the front, the center and the rear areas of the rod box do not exceed their respective maximum load capacity.

7 Checking before driving

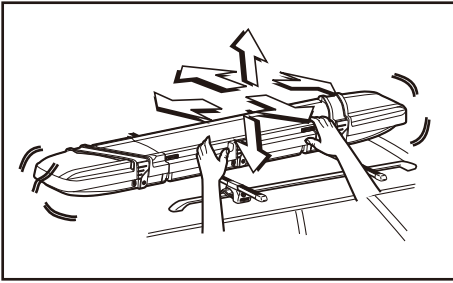

1 Shake the rod box in all directions, right and left, backward and forward, and up and down, to look for any rattling caused by improper installation. If you still hear or feel rattling, go back to Section 4 "Installation of the Rod Box" on page 7, and repeat the tightening procedures to re-tighten the two installation positions.

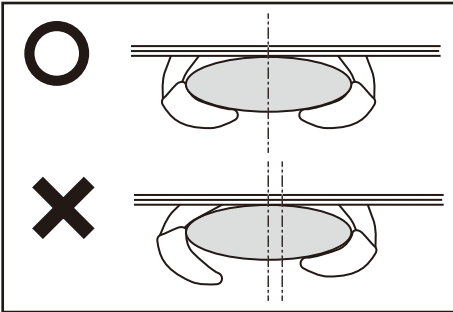

2 Make sure that the memory mount hooks are symmetrically positioned. If the center between hooks matches the base rack center, they are correctly positioned.

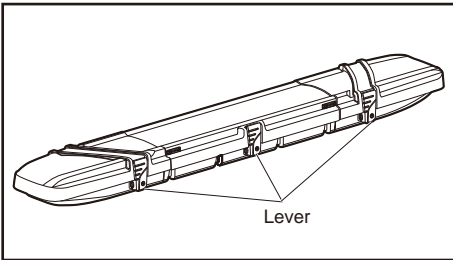

3 Check that the three levers are securely closed, and the keys are locked.

8 Daily Maintenance / Storage

If the rod box becomes dirty, wash it with water.

Warning

To avoid deterioration of the Rod Box material, do not use detergent, wax or thinner. Do not oil the lock and the hinge portions.

If you do not plan to use the rod box for a long period of time, remove the rod box from the vehicle roof, inspect every part of it, and store it away from direct sunlight.

Note

Watertight molds on Cover A and C are subject to wear and tear. If you notice they have allowed a lot of water inside the rod box, replace them with new ones.

Note

The rod box materials gradually deteriorate due to exposure to UV light. If you do not plan to use the rod box for a long period of time, store it away from direct sunlight, high temperature, and high humidity.

Repair parts

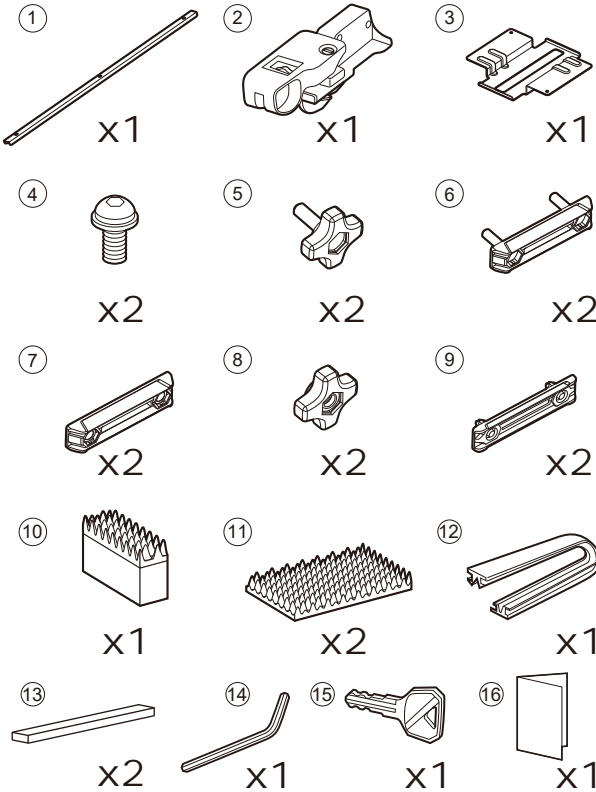

No.		Part name
①	ISP1130	Frame
②	ISP1109	Memory mount *
③	ISP1131	Bottom plate
④	ISP833	Hexagonal concave bolt (Set of installation bolts)
⑤	ISP1132	Knob bolt
⑥	ISP1133	Joint bolt
⑦	ISP1134	Joint nut
⑧	ISP1135	Knob nut
⑨	ISP1136	Filler cap
⑩	ISP1137	Grip cushion
⑪	ISP1138	Bottom cushion
⑫	ISP270	Mold L (Filler mold)
⑬	ISP1009	Watertight mold (800 x 2)
⑭	ISP17	Hex Wrench
⑮		Key
⑯		Installation instructions

*Repair parts come with a key.
You cannot designate a key No.

Check the key No.

Contact Information

We do not accept any liability for accidents, damage or injury caused by incorrect installation or use, modification, or natural disaster. Specifications and appearance of the rack system and genuine replacement parts are subject to change without prior notice in the interest of product improvement.

CARMATE MFG. CO.,LTD.
5-33-11, Nagasaki, Toshima-ku, Tokyo
171-0051, JAPAN
TEL. +81(0)3 5926 1226
int@carmate.co.jp

CAR MATE U.S.A. INC
383 Van Ness Ave, Suite 1603
Torrance, CA 90501, U.S.A.
www.innoracks.com
support@innoracks.com