

Installation Instructions

Before using the Mounting hooks, carefully read this installation instruction as well as the installation instructions for basic carrier systems, and follow all usage instructions. After reading the manual, keep it in a safe place along with the installation instructions for basic carrier systems. If you are to give the mounting hooks to a third person, provide this manual to ensure safe installation and usage. If you have any questions regarding this manual, please contact the service center listed at the end.

- Read instructions matching the model, year and type of vehicle.
- If appropriate instructions are not available, contact us listed below.

Precautions

- Install hooks correctly at specified positions according to the instructions herein and instructions for the applicable carrier system. Installation positions of hooks depend on the vehicle type. If hooks are not installed at specified positions, the carrier may fall and cause an accident. If instructions appropriate for your car are not available, contact our service center listed below.
- Select hooks matching your car by referring to the Fit Guide available at the store at web : www.innoracks.com.
If inappropriate hooks are used, the carrier / attachment may drop and cause accident.
-Before driving the vehicle, rock the stays and bars in all directions to ensure that there is no looseness. Retighten any loose knobs or bolts.
- Do not use these hooks for attachments of non-specified types.
The carrier may drop and cause accident.
- Observe the specified loading conditions.
Failure to observe the loading condition may cause the carrier to break or loosen and drop, resulting in accident.

For INNO dedicated ski & snowboard carriers read carrier instruction manuals for determining proper mounting locations.

The TR Mounting hooks includes the parts listed below. Verify that all of these parts are included in the carrier system you have purchased. In the event any of these parts is missing, contact us as listed at the end of this manual.

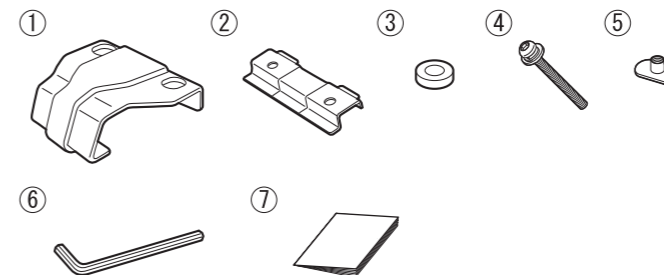

No.	Parts	Qty
①	Front hook	4
②	Rear hook	4
③	Spacer rubber	8
④	Bolt [M6x40mm]	8
⑤	T-nut	8
⑥	Allen key [B=4]	1
⑦	Instruction manual	1

Note

Installation procedures are described for different models, years and types.
If your car doesn't match any of the vehicle types listed, refer to the instructions for the applicable carrier.

Contact Information

If you have any comments, questions or suggestions, please contact us at the service center listed below. Car Mate USA shall not be held liable for any accidents or incidental losses arising from improper installation or use, nor for those arising from installation or use after the customer has made any modifications to the system's original configuration or specifications. If you can not find your vehicle on the following page(s), please contact us to get your vehicle informations.

CarMate USA www.innoracks.com
383 Van Ness Avenue, Suite 1603
Torrance, CA 90501
support@innoracks.com

TR102 Installation Procedure for the individual Vehicle Model

Manufacturer	Vehicle model	Vehicle type	Model year	Loading conditions	
				Maximum Load Capacity	Bike
SUBARU	FORESTER	w/ Roof rail	Feb. 1997 - Feb. 2002	40kg (loaded items + attachment)	2 bikes

*Use TR104 for the low type roof rail (already attached to STi-II. Feb.2000 - Feb.2002).

Vehicle preparations

1 Clean the roof rail of the vehicle.

Installing System Carrier (IN-TR)

Parts preparations

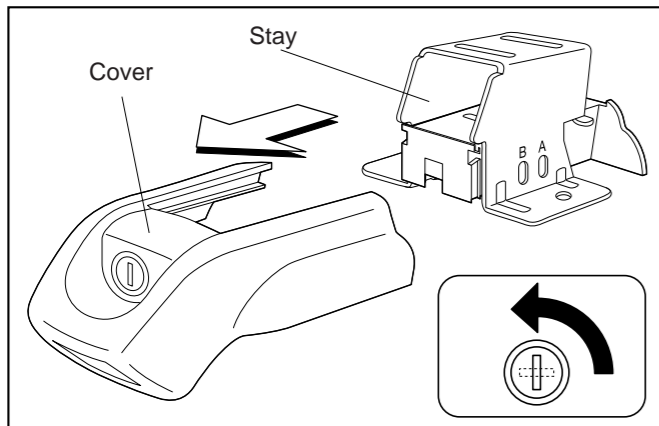

1 Unlock the key of your Basic Stay TR and remove the covers from the stays.

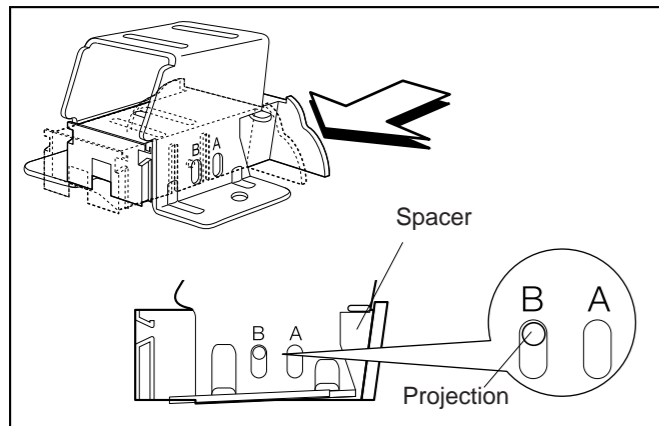

2 Slide the spacer so that the projection is positioned at the B hole.

3 Place the bolts through the carrier, rubber spacer, front hook and rear hook in this order and loosely screw the bolts. Verify the direction of the T-nut in doing this. Repeat this procedure for the opposite end.

Caution

- Verify the directions of the T-nut projection and the rear hook for proper installation.

Reference

Tip of the bolt should not protrude from T-nut.

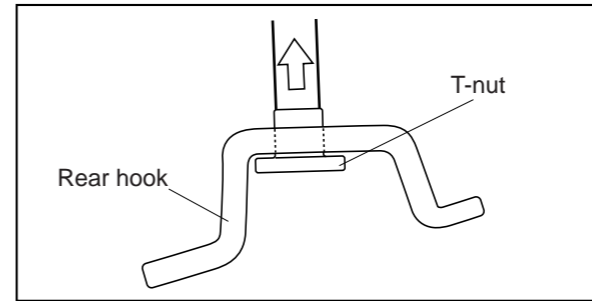
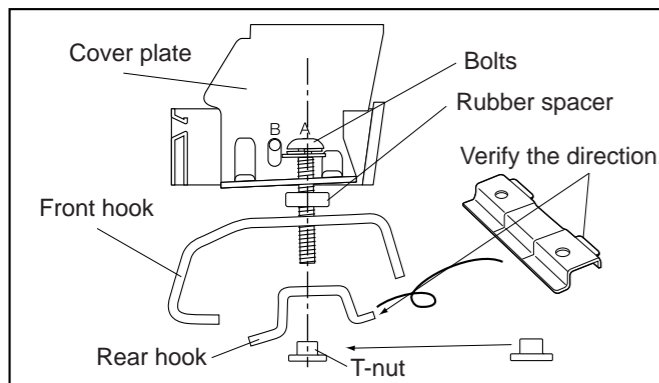

4 Insert the T-nut projection into the hole of the rear hook.

Repeat the procedure to install all 4 stays.

Mounting on vehicle

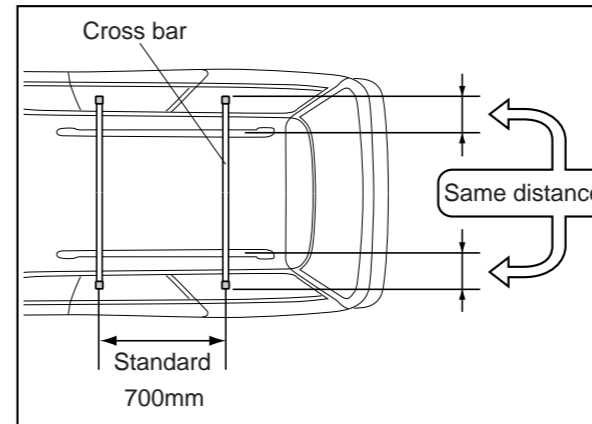

1 Lay the cross bars vertically against the roof bars.

Caution

- Be sure that the center of the cross bar is positioned at the center of the vehicle.

Reference

In installing front and rear cross bars, select an appropriate distance between 500mm and 800mm between the bars depending on the length of the load. Standard distance is 700mm. Short loads such as child skis will be stabilized at short distances between the bars.

When loading longer loads such as boats and roof boxes will require longer distances between bars for better stability.

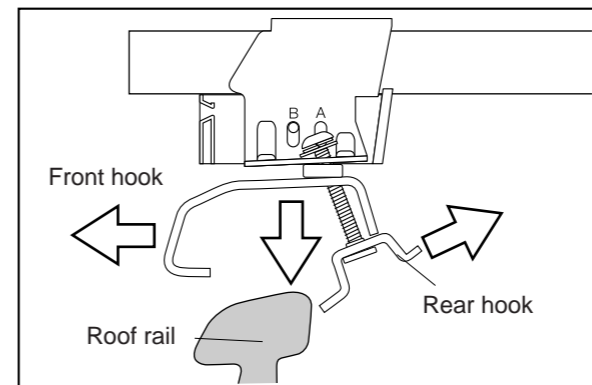

2 Insert the bar into the assembled stay. Open the front hook and rear hook manually, and place them on the roof rail.

Reference

The surface of the cross bar with 8 grooves must face up.

Tip of the bolt should not protrude from T-nut. Loosen the bolt before installing.

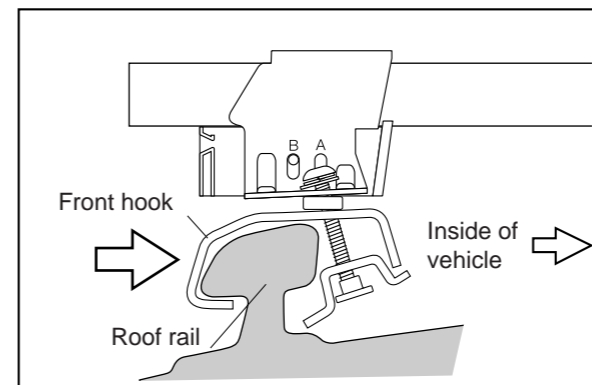

3 Slide the front hook so that it is pressed onto the roof rail.

Caution

- Check the spacer projection mode (see page 2).

Repeat the procedure on all 4 locations (right, left, front and rear).

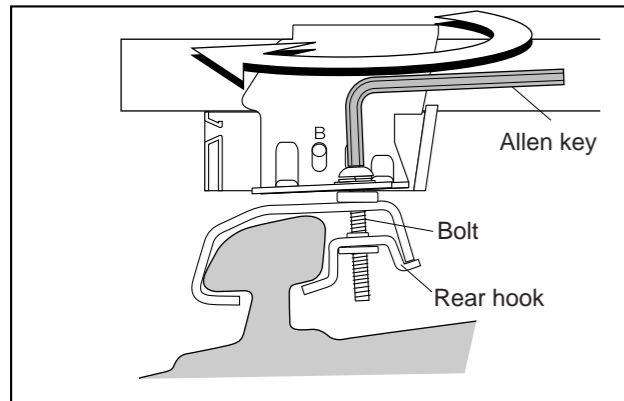

4 Tighten bolts alternately using the attached allen key and fixate the stay onto the roof rail.

Caution

- Be sure that cross bars are placed vertically across the direction of the vehicle.
- Tighten the bolt until the spring washer lies flat.

Reference

Tighten bolts loosely with hands first, and tighten further using the Allen key.

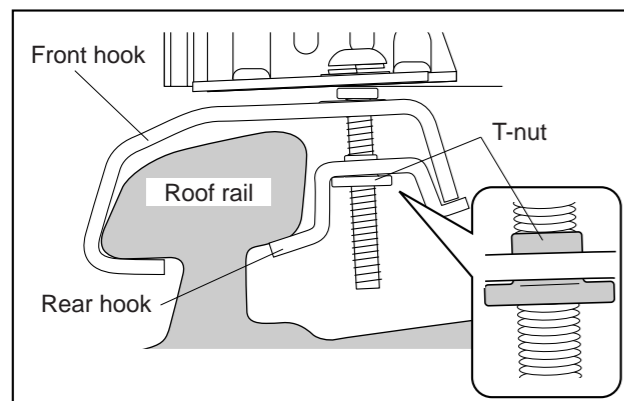
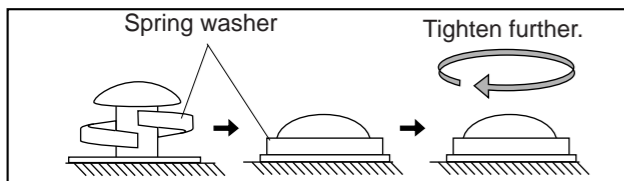

5 Verify that the rear hook is securely fastened and that the T-nut is firmly inserted into the hole of the rear hook.

Repeat the procedure on all 4 locations (right, left, front and rear).

6 Close the cover and the bar end cap. Insert key and turn right to lock.

Warning

- Always use the key lock to secure the carrier. The locks are an extra safety measure preventing racks from coming loose which may result in serious injuries and/or accidents.

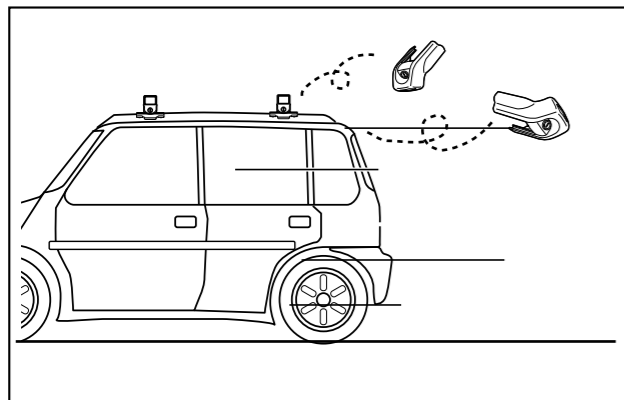
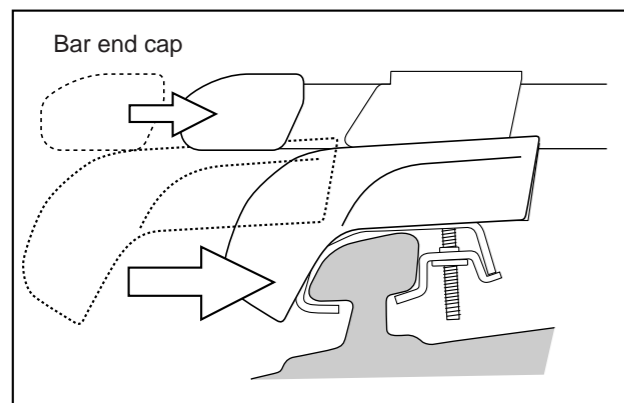

Installing Other Winter Carriers (TX###)

Warning

These carriers require the appropriate fit hooks for your vehicle type which are sold separately. Each fit hook style has a unique installation method. For the correct fit hook set for your vehicle, consult the fit guide which is available at our service center, your dealer, or online.

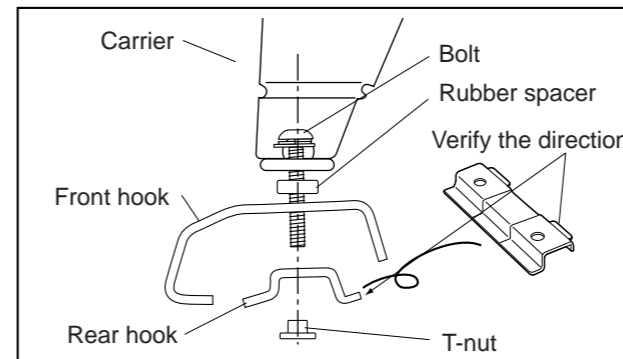

1 Place the bolts through the carrier, rubber spacer, front hook and rear hook in this order and loosely screw the bolts. Verify the direction of the T-nut in doing this. When mounting on the vehicle, see page 3 and follow the same procedure for mounting the system carrier.

Caution

- Verify the orientation of base plate and hook plate.
- The short bolts (M6x15mm) that are included in the winter carrier are not used.

2 The rest of the procedure should be followed in accordance with the instruction manual of the winter carrier.

After installation

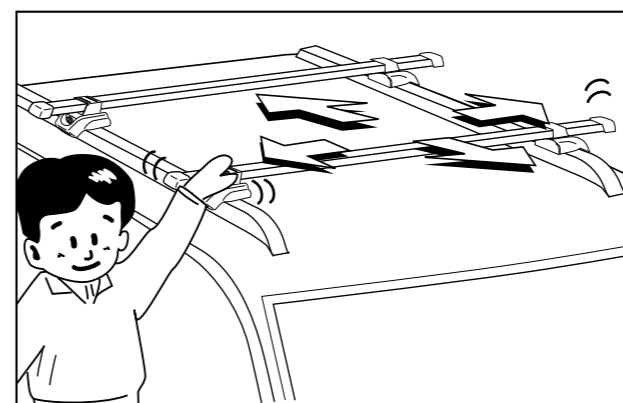

Warning

- Before driving, shake the installed stays and bars in order to check that all 8 bolts are securely tightened. If loosely screwed bolts are found, tighten them immediately. Loose bolts may lead to separation of stays, attachments and the load due to wind pressure and vibration while driving, resulting in serious injuries and/or accidents.