

The following Installation Instructions explain how to mount and use the carrier designed for loading skis & snowboards. After reading this manual keep it in a safe place for future reference. If you have any questions regarding the information in this manual, please contact the service center listed at the end.

The UK729 includes the parts listed below. Verify that all of these parts are included in the carrier system you have purchased. If any of these is missing, contact our service center listed at the end of this manual.

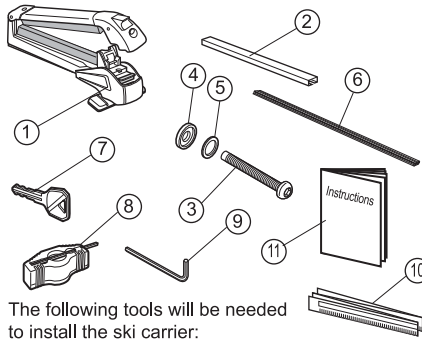

No.	Part	Qty
①	Carrier	4
②	Frame	2
③	Bolt	4
④	Washer	4
⑤	Plastic Washer	4
⑥	Rubber seal	1
⑦	Key	2
⑧	Torque knob	1
⑨	Hex wrench (S)	1
⑩	Tape measure	1
⑪	Instruction	1

* The bolts are attached into the carriers.

The following tools will be needed to install the ski carrier:

Tool	Qty	Tool	Qty
Scissors	1	Tape Measure	1

⚠ Precautions

This carrier requires the appropriate fit hook set and may need UK joint bars depending on type of vehicle. Be sure to check the Fit Guide.

1 Before installing your rack, clean the surfaces of your vehicle's roof and remove any side visors, sunroof visors or antennas, if they are mounted in a place interfering with the roof rack, snowboards or skis.

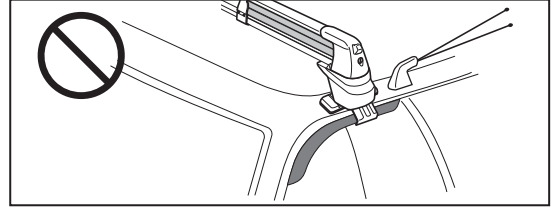

⚠ Precautions

Installing the rack on a sun visor may cause it to come off accidentally.

2 Determine the width of the front and rear racks. See Fit Hook instructions for Stay interior dimension. Use the attached tape measure and align the A measurement with the center sticker on the center frame.

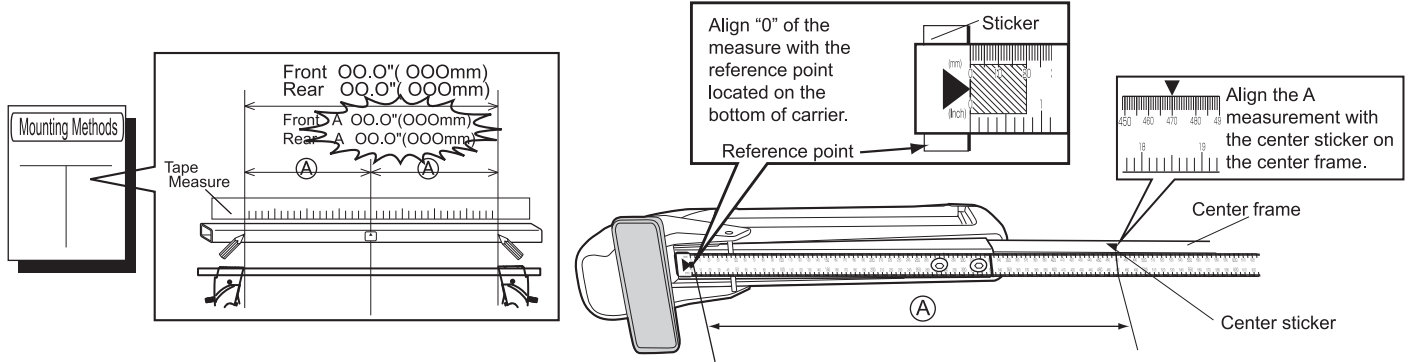

3 Loosen the bolts underneath the rack so that the frame can be inserted. Be careful not to unscrew the bolts completely from the plate inside the rack.

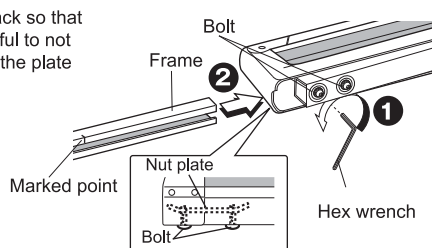
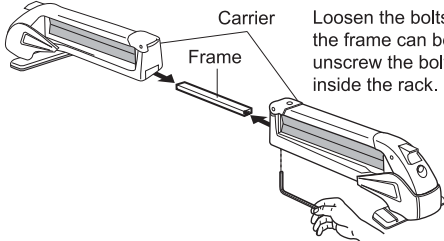

4 Slide frame into rack up the points marked in step 2.

⚠ Precautions

If the bolts are separated from the plate, install them again with the plate in the correct orientation.

5 Securely tighten the 4 bolts until the lock washers become flat. Then give them one more full turn.

⚠ Precautions

Securely tighten all 8 bolts on the front and rear carriers.

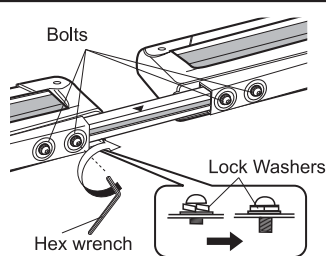

6 Center the frame by aligning the center sticker with the center of the car.

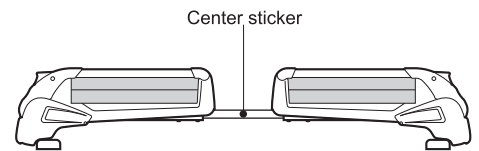

7 Trim the rubber seal to fit the slot under the frame. Slip one side of the seal into the groove and then the other side with fingers.

1. Slip one side
2. Push in the other side
3. Make flat

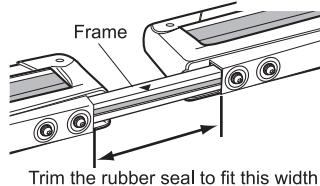
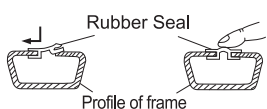

8 Front and rear mounting points and proper rubber base numbers can be found in the Fit Hook instructions.

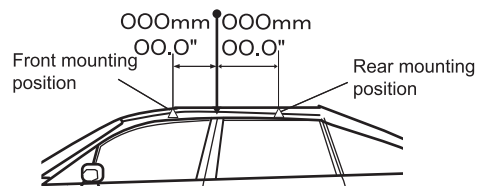

Mounting Method

Install bases

	Base number
Front base	000
Rear base	000

9 Place the carrier on the rubber bases and center the carrier over the car.

⚠ Precautions
May vary by vehicle. Refer to the instructions included with the Fit Hooks.

1 Carrier
Base

2 Center sticker
Center of the car

10 1. Turn key counter-clockwise and open the clamp.
2. Pull back and lift up cover.

Button
Lock
Cover

📖 Note
This is a safety feature that prevents the key from being removed until key is in a lock position. After opening the clamp arm, turn the key to the lock position, and remove the key.

11 Insert hook, washer and plastic washer into the thread with bolt by hand first 3 turns and then, tighten by hex wrench to avoid damage on the thread.

⚠ Precautions
Some vehicles have different hooks for front & rear, right & left. Refer to the Mounting Methods manual included with the Fit Hooks.

Washer
Plastic washer
Thread
Hook
Bolt

Mounting Methods
Loosely attach hooks.

	Hook number
Front base	000
Rear base	000

12 Evenly tighten bolts left and right alternatively until the included torque knob rotates freely.

⚠ Precautions
Excessive tightening may damage the vehicle's roof and/or molding edge. Do not tighten the bolts any more than is necessary.

Thread
Hook
Torque knob

13 Lower the cover and push it in. Lower the blue lever. Close the cradle clamp. Insert key and turn key right to lock the rack.

Before driving the vehicle, try to rock the carrier in all directions to ensure that it is securely fastens. Retighten any loose knobs.

Lever
Cover
Lock

14 Carrying capacity is as follows. This carrier is only designed to carry skis, ski poles and snowboards. Do not attempt to carry any other items.

Carrying Capacity

Ski	6 *1
Snowboard	4 *2
Snowboard & Ski	2 Snowboards *2 + 3 Skis *1

*1. Loadable quantity could be less than this number based on width of skis (ie: carving skis).
*2. Loadable quantity could be less than this number based on the size of binding or the distance to the car roof.

15 Final Check

⚠ Precautions
Check all knobs, bolts, width-adjustment screws and any other mounting hardware on a periodic basis to make sure that they are securely tightened.

Mounting position of Hook and Base
Hook
Base
*This carrier corresponds to IN-SU like this.

16 To adjust the cradle angle, first open clamp by pushing the button above the keyhole. Then lift up the blue lever and pull it back. While holding the back lever, pull up or push down on the cradle to raise or lower it.

⚠ Precautions
Do not adjust the cradle angle during loading skis or snowboards.

Cradle
Blue lever

17 Installation notes

- With clamps open, put skis or snowboards on the carriers. Their rear end must be positioned toward the front of vehicle.
- Slide skis or snowboards to the rear carrier until their bindings hit.
- Do not carry skis or snowboards if they come off of the front or rear carriers.
- Repeat by sliding skis or snowboards to the front carrier until the bindings hit.
- Do not carry skis or snowboards if they come off of the front or rear carriers.

Ski
Snowboard
Front of vehicle

18 Loading notes

Ski pairs may be loaded back-to-back or side-by-side. If loading side-by-side, load so that the front carrier is between bindings. This loading style can also be used if bindings don't fit within the space of both carriers. Length A must be no more than 90cm [35"]. The difference of thickness between pairs of skis and snowboards loaded on the same carrier must not exceed 10mm [0.4"] or there may not be sufficient grip on the board.

⚠ Precautions
Maximum thickness of skis or snowboards is 40mm [1.5"]
Less than 40mm (1.5")

Length A: Within 90cm [35"]
Less than 40mm (1.5")

Genuine INNO Replacement Parts

The following genuine replacement parts are available for this Inno carrier system component.

📖 Note
Specifications and appearance of the carrier system and genuine replacement parts are subject to change without prior notice in the interest of product improvement.

Key (specify number)
Rubber seal ISP101
Hex wrench(S) ISP19
Bolt Set ISP55
Rubber cushion upper
Rubber cushion lower
Torque knob ISP863
Set of bolt (four for one) ISP96
Instructions

For Safe Use

Before using the Carrier System, carefully read these guidelines as well as the installation and usage instructions for all the components that make up the carrier system. After reading these guidelines, keep them in a safe place with the instructions for the rest of the carrier system. If you give the Ski & Snowboard Carrier to a third person, provide this manual to ensure safe installation and usage. If you have any questions regarding this manual, please contact the service center listed in the installation instructions.

Warning

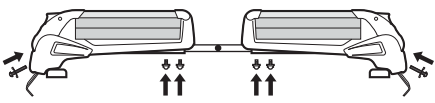

Check the fastening knobs and bolts, width-adjustment screws and any other mounting hardware on a periodic basis to see that they are securely tightened.

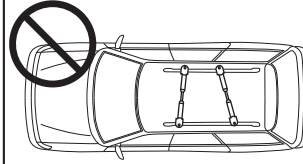

The front carrier and the rear carrier must be installed parallel against the vehicle.

50 MPH

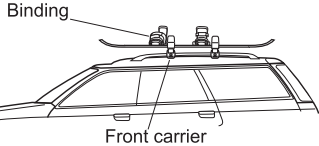

If there isn't sufficient bindings clearance between the front and rear carriers, load the ski and snowboard so that one of the bindings can be placed in front of and come in contact with the front attachment. Do not drive the vehicle speeds in excess of 50 mph.

This carrier is designed for carrying ski, pole and snowboard. So, Do not load any things except the above stuff.

Ski	6 *1
Snowboard	4 *2
Snowboard + Ski	Snowboard2 *2 + Ski3 *1

*1) Loadable quantity could be less than these numbers based on the width of skies like curving skies.
*2) Loadable quantity could be less than these numbers based on the size of binding or the distance to the car roof.

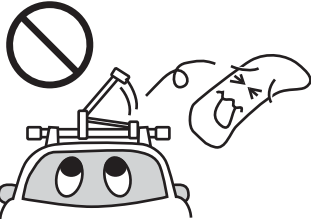

Always lock the attachment system with the key when loading the skis/snowboard. Failure to do so may cause the gear to come off when a certain amount of external force is applied to it, resulting in an accident involving the vehicle(s) behind and drivers and/or passengers in those vehicle(s).

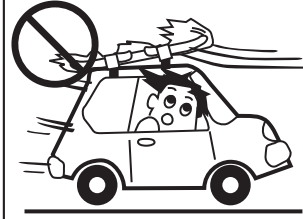

When loading a snowboard or pair of skis, do not use the gear casing or protective plastic packaging.



The carrier system's compatibility with an automobile is determined by the type of stay used. Be sure to check the FIT GUIDE, which is available at the store.



Do not exceed a speed of 80 mph (130km/h) when carrying ski or snowboard. And observe legal speed limit. Also, reduce your speed accordingly when driving in strong wind conditions or in bad road conditions.

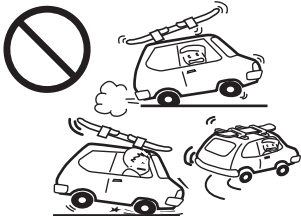

When using the Carrier System, avoid driving at excessively high speed. Do not make hard starts, unnecessarily sharp turns, abrupt maneuvers or emergency braking. In case you have to perform a sharp turn, abrupt maneuver or emergency braking, always check afterwards to see that the carrier system and cargo remain secure.



Always remove the carrier system before running your car through a car wash.

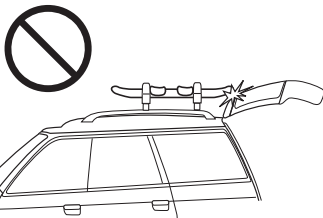

Be careful not to hit the ski or snowboard with the vehicle's tailgate or trunk lid. In case your gear is accidentally hit by the tailgate or trunk lid, be sure to check the carrier's mounting condition.

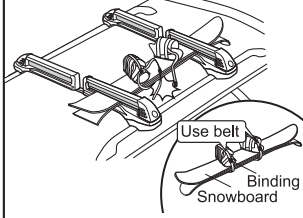

When the bindings or the lease code hit the roof or the roof rail, use the belt and tighten them.

Daily care and storage

Remove carrying system from vehicle when not in use. Avoid direct sunlight and store at dry place.

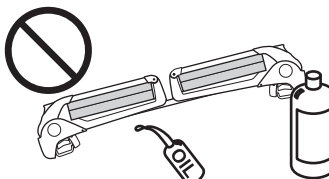
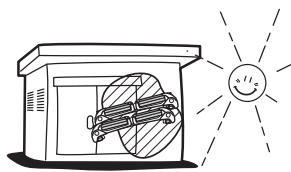

Precautions

-DO NOT lubricate Key and Bolts.
-DO NOT apply thinner and/or solvent as they may damage plastics.

Contact Information

If you have any comments or suggestions, please contact our service center listed. CAR MATE USA shall not be held liable for any accidents or incidental losses arising from improper installation or use, nor for those arising from installation or use after the customer has made any change to the system's original configuration or specifications.

CAR MATE USA, Inc.

383 Van Ness Ave., Suite 1603
Torrance, CA 90501 U.S.A.
support@innoracks.com
www.innoracks.com