

MV276

Installation and Usage Instructions



The following Installation Instructions explain how to mount and use the carrier designed for loading skis & snowboards. After reading this manual keep it in a safe place.

If you have any questions regarding the information in this manual, please contact the service center listed at the end.

1 The MV276 includes the parts listed below. Verify that all of these parts are included in the carrier system you have purchased. If any of these is missing, contact our service center listed at the end of this manual.

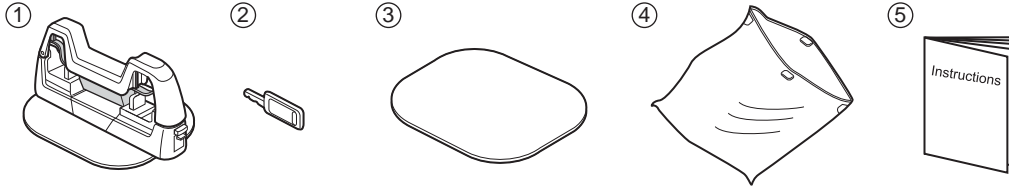

No.	Part	Qty
①	Carrier	2
②	Key	2
③	Protect sheet	1
④	Plastic bag	1
⑤	Instruction	1

2 Before installing your carrier, clean the surfaces of your vehicle's roof and the magnetic sheets.

3 Decide the installation position. Follow these guidelines in choosing the right spots:

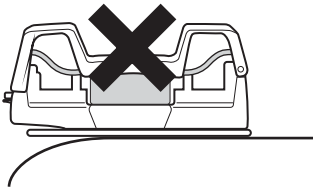

CAUTION
When on the roof, the entire magnetic pad must contact the roof.

At least **13.7"** (35cm)

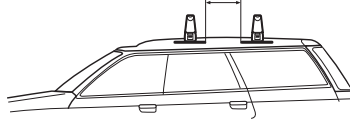

CAUTION
There should be a distance of at least 35 cm (13.7") between the front and rear carriers.
Be sure to check the ski/snowboard's loadability according to the procedure described in the installation instructions below.

4 Place carrier on the roof gently. If you need to change the carrier's position, do not attempt to slide it along the roof. remove the carrier from the roof completely to change its position. See the removal section below for details on how to remove the carrier once installed.

5 Carrying capacity is as follows. This carrier is only designed to carry skis, ski poles and snowboards. Do not attempt to carry any other items.

Carrying Capacity

Ski+Pole	2+2 *1
Snowboard	1

*1) Loadable quantity may vary based on width of skis (ie: carving skis).

6 Open the key cover and turn the key clockwise to unlock.

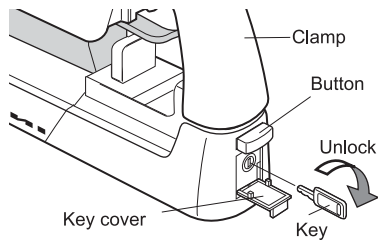

7 Push the button and lift to open clamp for loading.

8 Installation notes

- ① With clamps open, put skis or snowboards on the carriers. Their rear end must be positioned toward the front of vehicle.
- ② Slide skis or snowboards to the rear carrier until their bindings hit.
- ③ Do not carry skies or snowboards if they come out of the front or rear carriers.
- ④ Repeat by sliding skies or snowboards to the front carrier until the bindings hit.
- ⑤ Do not carry skies or snowboards if they come off of the front or rear carriers.

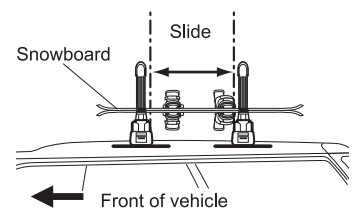
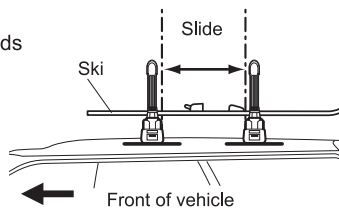

9 Loading notes

- To reduce wind resistance, the tail of skis or snowboard must be toward the front of the vehicle.
- Keep clamp closed except when loading to prevent icing on the mechanisms.

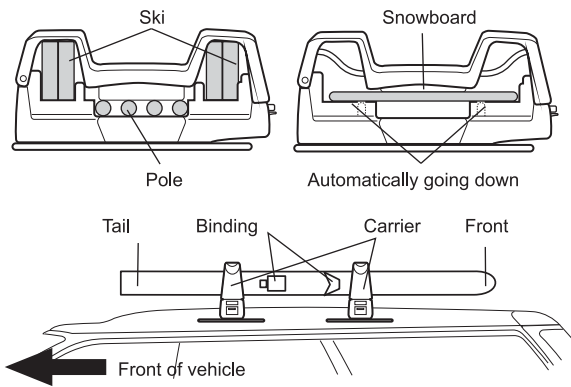

- Maximum thickness of skis is 40mm[1.5"].
- Maximum thickness of snowboard is 19mm(0.75").

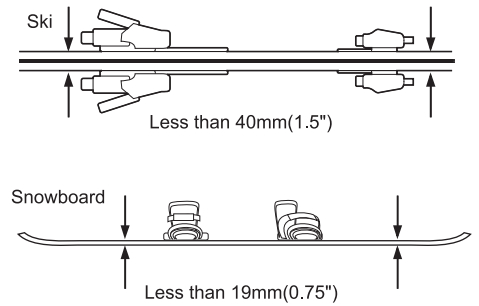

10 Removing the carrier

Open the key cover and turn the key clockwise to unlock.

Push the button and lift open the clamp.
Pull the hook back toward the button.

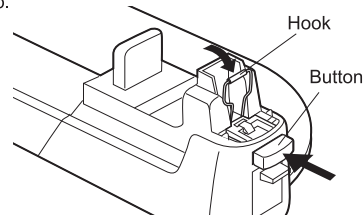

Pull the hook upward to break the magnetic seal and remove carrier.

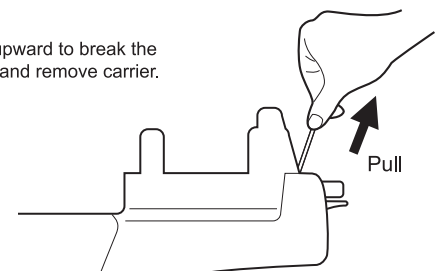

11 Removal and Misc. notes

- Do not remove carrier in freezing conditions, such as at a ski area, since a sheet of ice might form on the roof preventing proper reinstallation of the carrier on the roof.
- Replace the rubber bands immediately when you notice any cracks on them.
- Be careful to keep items that can be damaged by the carrier's magnetic field, such as watches, credit cards, compasses, and computer disks, away from the carrier's magnetic pad.

12 Care and Storage

- Wash any mud off the carrier system. If necessary, use only a mild detergent to clean the carrier.
- Use a damp cloth to wipe away dust and dirt.
- For storage purposes, the carriers may be attached to each other back-to-back. Because of the strong magnetic force, always insert the protect sheet between them to allow for easier separation. And then put them into the plastic bag.

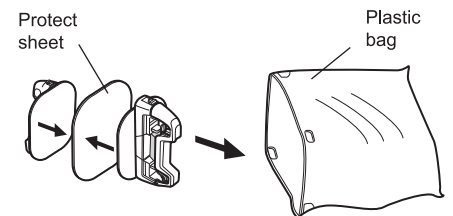

Genuine INNO Replacement Parts

The following genuine replacement parts are available for this INNO carrier system component. Specify the part number when ordering parts from your dealer.

Note

The specifications and appearance of the carrier and genuine replacement parts are subject to change without prior notice in the interest of product improvement.

Contact Information

If you have any comments or suggestions, please contact our service center listed below. Carmate USA shall not be held liable for any accidents or incidental losses arising from improper installation or use, nor for those arising from installation or use after the customer has made any modifications to the carrier's original configuration or specifications.

CAR MATE USA, Inc
383 Van Ness Ave. Suite 1603
Torrance, CA 90501 U.S.A
www.innoracks.com

Guidelines for Use of Ski & Snowboard Carrier

Before using the Magnetic Ski & Snowboard Carrier, carefully read these guidelines as well as the installation and usage instructions.

After reading these guidelines, keep them in a safe place for future reference.

If you give this carrier to another person, give them this manual to ensure safe installation and usage. If you have any questions regarding the information in this manual, please contact the service center listed in the installation instructions.

⚠ Precautions

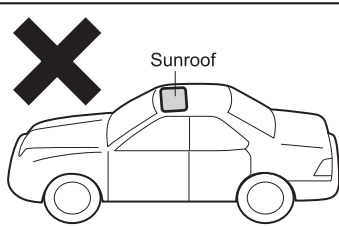

This magnetic carrier should be installed only on smooth roofs without features such as sun roofs, T-tops, targa tops, ribs, luggage racks, etc. The carrier should be installed on a flat area to avoid ribs or if car has.

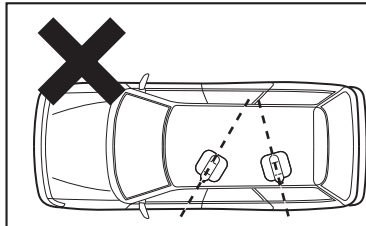

The front and rear carriers must be installed parallel to each other.

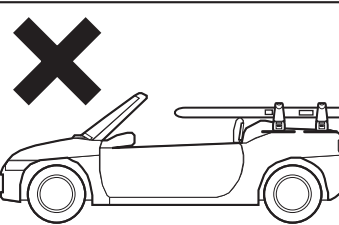

This magnetic carrier is designed for the roof top only. Do not attach to the door or trunk or hood.

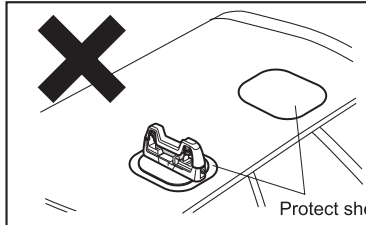

Do not use any stickers or protective sheets between the carrier and the car roof. The magnetic pad must sit directly on the roof.

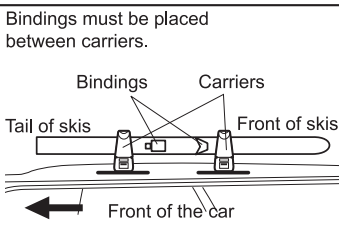

Both bindings must be placed between the front and rear carriers. The tail end of the skis and snowboards should be toward the front of the car to reduce wind resistance.

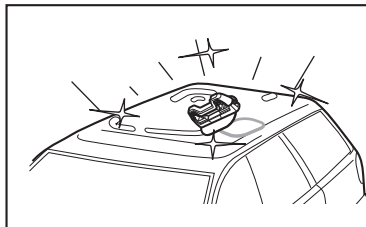

This carrier is designed to mount to the car roof using magnetic power. It is important to keep the roof surface clean and free from ice, snow, water, sand, dust and other contaminants that can come between the carrier and the roof while driving. Failure to do so may allow the carrier to fall off accidentally.

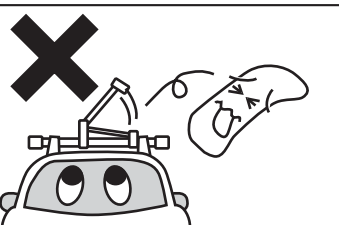

Always lock the carrier with the key when carrying skis/snowboards. Locking the carrier will help prevent accidental opening and damage to your equipment.

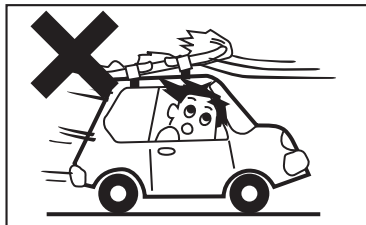

When loading a snowboard or pair of skis, do not use gear bags or cases or protective plastic packaging.

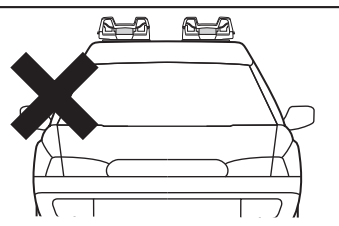

Do not install more than 1 set of carriers on a car to prevent damage to the roof or accidental release of the carrier from the roof.

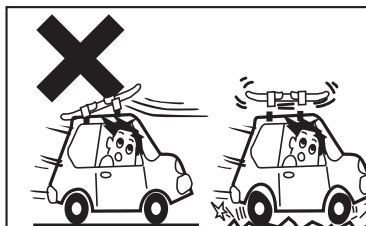

After driving continuously at high speeds for some time, at a regulated speed due to bad weather conditions, or when driving over rough roads, check to see that the carrier and cargo are still securely mounted.

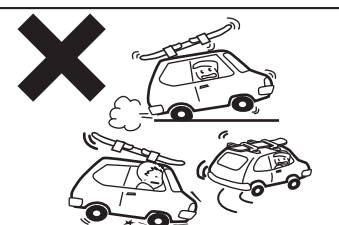

Always observe the rules of safe driving. While using this carrier, avoid driving at excessively high speeds. Do not make hard starts, unnecessarily sharp turns, abrupt maneuvers or emergency stops. In the event that you need to perform such a maneuver, always check afterwards to make sure that the carrier and cargo remain secure.

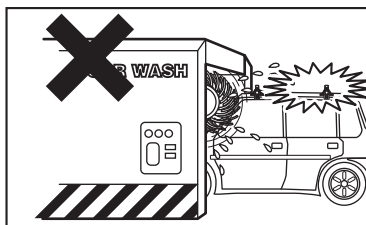

Always remove the carrier before running your car through a car wash.

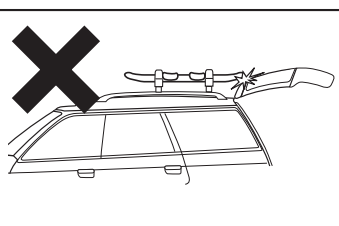

Be careful not to hit the skis or snowboard with the vehicle's tailgate or trunk lid. In case your gear is accidentally hit by the tailgate or trunk lid, be sure to check the carrier's mounting condition.

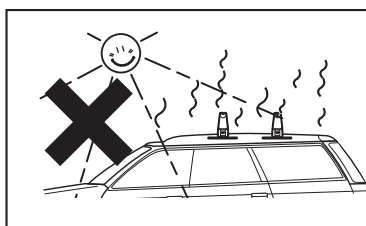

Do not leave the carrier mounted to the car roof in temperatures exceeding 86°F. Such excessive temperatures may cause the magnetic pad to lose its ability to adhere to the roof.